

\$6.95 US.

THE OFFICIAL PUBLICATION OF THE INTERNATIONAL ASSOC FOR ALL TRIKE RIDERS

TRIKER MAGAZINE

SEPT/OCT 2017

*Come Ride
with BTW*

CHECKOUT OUR NEW ITEMS FOR
SALE ON THE INSIDE COVER

BROTHERS OF THE THIRD WHEEL
PO Box 2550 Cortaro, Arizona 85652

E-mail: trikers@btw-hq.net - 520-789-7265 - Website: www.btw-trikers.org

NEW BTW ITEMS



7" btw SPYDER RYDERS Rocker
(can be worn above the BTW Back Patch)
\$6 ea



BTW Koozies
Choice of Red or Tan
\$1 ea or 5 for \$4



Custom BTW large Trophie Mugs
5 1/4" tall with your choice of
Engraving on the plate
\$22 ea



Custom designed dropped neck
Ladies T-Shirts with side logo
S-XL \$20 2XL - 4XL \$25

TRIKER MAGAZINE

SEPT/OCT 2017

CONTENTS

| | |
|-------------------------------|----|
| New Products for Sale | 2 |
| Letter from Headquarters | 4 |
| Product Catalog..... | 8 |
| Member Rides | 15 |
| From The Web | 18 |
| BTW Event Flyers..... | 20 |
| From The Industry | 22 |
| Classifieds..... | 23 |
| From The Members | 28 |
| New Benefits for Members | 32 |
| Around The World on Trikes | 34 |
| BTW SWEDEN | 48 |
| BTW France | 49 |
| Of Interest | 51 |
| Vendor partners | 58 |
| Events Calendar | 59 |
| In Memory of | 61 |
| Director Guidelines | 62 |
| Directory | 63 |
| BOD Elections | 70 |

**CHECK OUT ALL THE NEW PRODUCT
IN THE CATALOG**

Disclaimer:

BTW/Triker Magazine does not assume liability for any products or services listed in this publication. BTW/Triker Magazine does not assume any liability for loss or damage due to errors/omissions, products, or services listed (including, but not limited to materials and techniques used to convert motorcycles into three-wheeled Trikes). Every effort is made to ensure the information in this publication is correct at the time of printing.

Triker Magazine is a bi-monthly publication published by Brothers of the Third Wheel and printed by Sundance Press (Tucson, AZ).

We welcome your submissions (stories & photos) pertaining to trikes/BTW. We MUST receive these by the end of the first week of Dec. Feb. Apr. June. Aug. Oct. in order to be in the next publication.

FOR ADVERTISING INFORMATION

Please contact Alex at 520-334-0534
or E-mail alex@btw-hq.net

PLEASE SUBMIT ALL PHOTO & ARTICLES TO:

Email: trikers@btw-hq.net
Ph: 1-(520)-789-7265

Submissions will not be returned and
are subject to editing/alterations.

BACK COVER:

**One of our Pet Riders looking for a
bitch rider
(Hey Baby wana ride)**

From your BTW Headquarters

First I would like to thank all those who attended the National Trike-In in Dodge City and made it such a great event. As you will see from the photos in this issue the facilities were wonderful, having Trike Central in the air conditioned pavillion made it special, and the Trike show on the grass just outside with the vendors was perfect. I also had many great comments about the Hotel used for the event which was undoutably the best hotel in the city. The Boothill shows and dinner was a big hit. The locals turned out in big numbers to watch the police escorted light parade through town. I would personally like to thank all the staff of the Dodge City Convention and Visitor's Bureau, especially Jan & Megan for all the help and support given BTW. We are currently awaiting the evaluations to be returned, so we can start planning next years event and implementing all your suggestions, We have added several new items in the store, at the request of our members and encourage all members to let us know what they would like to have available as a BTW item.

As you can see from all the photos of events in this issue, it is a busy time for events right now and from the looks of things a good time is being had by all. We work hard to get you advertisers with products of interest to our members and ask that you consider these companies when you need something to show our appreciation for their ads. If you use a Company for Trike products, please let them know that we have special rate for them to advertize in the TRIKER magazine, where they will be seen by trike riders all over the world. We will also help them to create the ad at no charge, if they need it.

We have lost several of our long time members recently and it is never easy to accept, I for one am having a hard time with the sudden lost of Churchy, who I called a friend and brother. I will miss him as I ride my trike and am sure he is up there riding with all of us.

Now for more sad news, Becky Brown has moved to the city and will no longer be working with us, I know most of you who have dealt with her will join me in wishing her well, with both her new surroundings and her new venture. She also just had her oldest daughter join the military and we wish her well also. Lynne will be covering this spot until Becky can be replaced, which hopefully will not take to long as I don't wish to get divorced. I look forward to getting to a few more events this year and also maybe take a vacation from BTW for a week or so later in the year. Ride safe and enjoy triking



**The Front Cover:
There is nothing better than a group ride
of trikers.**

**NOTICE:
The Financial Statement for 2016 is
completed and posted to the Web Site**

NEW NEW NEW

NEW 2017 REDUCED ADVERTISING RATES

The **TRIKER** magazine is published 6 times per year on the **1st of JAN. MAR, MAY, JULY, SEPT, NOV**, All Photos & Material are run one time on a first come first used basis. All Classifieds are run twice unless notified to the contrary by HQ. DEADLINES FOR ALL MAGAZINE MATERIAL IS THE FIRST WEEK OF **DEC, FEB, APR, JUNE, AUG, OCT** FOR THE NEXT ISSUE

TRIKER CLASSIFIEDS:

All ads are free to members and \$30.00 per insertion for non-members for 2 issues. Payment must be received prior to deadline. Ads must be camera ready in one of the following formats, PDF, JPEG. in a minimum of 200 pixels

ADVERTISING RATES

| SIZE AD | DIMENSIONS | COST PER ISSUE | 1YR CONTRACT |
|--------------------|-------------|----------------|--------------|
| Inside Front Cover | 7.5" x 10" | \$650.00 | \$3,500 |
| Inside Back Cover | 7.5" x 10" | \$550.00 | \$2,900 |
| Full Page | 7.5" x 10" | \$400.00 | \$2,000 |
| Two Thirds Page | 7.5" x 6.5" | \$320.00 | \$1,700 |
| Half Page | 7.5" x 5" | \$250.00 | \$1,300 |
| Third Page | 7.5" x 3" | \$160.00 | \$ 850 |



LEES-URE LITE POP-UP TENT TRAILERS

Sleep anywhere in comfort!
Easily pulled by most touring motorcycles!



Lots of options to choose from!
A/C Kits, Add-a-Rooms, Awnings
Storage Solutions and More!!!

Save \$\$\$ on gas!!!

Call for a FREE brochure and price list!

1-800-660-0933

Website - www.tent-trailer.com

Email - info@leasurelite.com



BROTHERS OF THE THIRD WHEEL

2017 SPECIAL MEMBERSHIP OFFER

PURCHASE A NEW MEMBERSHIP



**AND YOU WILL RECEIVE
ONE MEMBER PATCH FREE**
(New Members choice of Intl. patch size)

**This offer is for any owner of a Trike
who has never been a member of BTW**

Current Riding Groups can start their own BTW Chapter



MEMBERSHIP APPLICATION FOR 2017

BROTHERS OF THE THIRD WHEEL

PO Box 2550 Cortaro, AZ 85652

E-Mail: trikers@btw-hq.net

Phone: 520-789-7265



Name: _____ Spouse: _____ Member #: _____

Address: _____

City: _____ State: _____ Zip: _____ Country: _____

Phone: (____) - ____ - _____ E-Mail: _____

Chapter Name: _____ Referred By: _____

Membership Fees: (North America Only) - Overseas Applicants contact HQ

New Membership with patch: Single Couple **Annual Renewal:** Single Couple

w/Online digital magazine \$57 \$63 \$34 \$38

w/printed magazine: \$67 \$71 \$45 \$49

Packages: Single Pkg: 5 yr 10 yr 15 yr Couples Pkg: 5 yr 10 yr 15 yr

Check/Money Order #: _____ Total Amount: \$ _____

Credit Card #: _____ Exp Date: _____ 3 digit security code: _____

Membership Packages

| (You access Digital magazine online) | Single | Couple |
|---|------------|-------------|
| 5 Year Silver Membership: w/digital mag. | \$149 | \$170 |
| w/Printed mag. | \$200 | \$220 |
| 10 Year Gold Membership: w/digital mag. | \$277 | \$319 |
| w/printed mag. | \$383 | \$424 |
| 15 Year Platinum Membership: w/digital mag. | \$418 | \$480 |
| w/printed pag. | \$579 | \$640 |
| New Membership Pkg can include a patch at discount price | Add | \$17 |

Mail: with payment to:
BTW HQ
 PO Box 2550
 Cortaro, Arizona 85652
 USA or
 Email:
trikers@btw-hq.net
 or
 on line at
www.btw-trikers.org

BENEFITS OF BEING A BTW MEMBER

- #1 BTW provides members with the only magazine in the world dedicated to Trike Riders and its membership on a bi-monthly basis.
- #2 BTW provides its members a membership card which entitles the card holder to special services and discounts for the many companies in the vendor partners section of the magazine.
- #3 Use of the BTW facebook page and all the chapter Facebook pages around the world.
- #4 Full access to the BTW website.
- #5 Sell or buy Trikes and associated items at no charge on the website classifieds.
- #6 Use the Tech Talk & Tips Services to get assistance from all the members.
- #7 The ability to post or just enjoy all the photos on the website.
- #8 Add or search for events on the website.
- #9 Use one of the many forums to ask your important questions regarding triking.
- #10 Take advantage of the discounts offered to BTW Members for facilities when traveling to other parts of the world.
- #11 Use the forums and linked websites to acquire info from other members in the world about any issues you need explained.
- #12 Post photos and videos of your ride, Trike, or event in both the magazine and on the website.
- #13 Check out the current information about trike related products in the “From the Industry “ section in the magazine.
- #14 Use all of these facilities to find riding partners any time.
- #15 Use the calenders to plan your next riding season and any events you might want to attend.
- #16 The ability to contact members for support anywhere in the world when you need assistance. That is our BTW Family.
- #17 BTW provides you with a central location and office with full time staff, to answer your needs.
- #18 BTW provides the largest base of information pertaining to trikes and accessories when you are trying to make a decision about what to buy and from whom.
- #19 BTW provides an extensive line of Association products for the membership at very reasonable prices both by phone or in the store on the website.
- #20 BTW provides you with promotion material to present to other perspective members in the form of the magazine, flyers and handlebar hangers.
- #21 BTW provides the membership the ability to submit stories, articles and photos to be posted in the Triker magazine.
- #22 BTW is continually adding more new benefits for its members and as a non profit Association this is its only purpose.
- #23 BTW MEMBERS ARE PART OF THE LARGEST INTERNATIONAL TRIKE ASSOCIATION THAT GIVES ANY PROFITS MADE TO LOCAL CHARITIES ALL OVER THE WORLD.

ALL THIS FOR A MEMBERSHIP FEE THAT, DOLLARS FOR SERVICES, IS THE LEAST EXPENSIVE MEMBERSHIP AVAILABLE IN THE WORLD.

BTW Product Catalog

SALE ITEMS



Style: "D" Black T-Shirt only
Specify: Size



Style: CA T-Shirt
Gold Rinstones
OR
Rainbow Rinstones
Specify Shirt Size & Color



Style "E" Black T-Shirt only
Specify: Size



Black T-Shirt w/ small White
BTW Logo on the Chest
Specify Size



NOW THAT YOU CAN SEE ME
on Lime Green T-Shirt only
Specify Size



JUNIOR TRIKER
Black only T-Shirt
SIZE: Youth Small - X-Large

T- Shirts Sizes: S - XL Regularly \$17 & \$20

SALE : Sizes S - XL \$13 2X - up \$16



BTW DECAL

LargeSize

8.5 x 12

Reg. \$15.00

Sale \$5

BTW Product Catalog

TO ORDER CALL 520-789-7265 or go to "www.btw-trikers.org"

ANNOUNCING BRAND NEW PRODUCT

NEW

PERSONALIZED OVERSIZE BTW MUGS

These unique Mugs are like no others with the embossed BTW LOGO and an ENGRAVED PLATE below for your name.

When ordering please state what you wish engraved on the plate. SIZE 5 1/4" TALL

Members only price \$22 ea.



NEW DECALS



CUSTOM ETCHED: 2 1/2" x 4" - ETCHED BTW LOGO FOR YOUR BUMPER, FENDER, GASTANK ETC.
OR 2 1/2" x 4" - REVERSED ETCHED BTW LOGO FOR THE INSIDE OF YOUR TRIKE WINDSHIELD

\$5.00 ea.

CUSTOM SILVER: 8 3/4" x 10" -- DECAL FOR THE OUTSIDE ON YOUR TRAILER, TRUCK DOOR ETC.

OR 8 3/4" x 10" REVERSED DECAL FOR THE INSIDE OF YOUR TRUCK WINDOW ETC.

\$15.00 ea.



You can now order any **RC Component** products through BTW if you are a member and receive a whopping **25%** Discount off their current retail prices. **This offer is not available anywhere else.**

How it works: go on their website at <http://www.rccomponents.com/> go to their catalogue write down the product number and all the required specifications.

THEN YOU MUST CALL BTW HQ to place the order and make payment. to receive your BTW member Discount.



forged
wheel
finishes



patriot
series
wheels



shift, brake
and foot
pegs



airstrike
high-reliability
air cleaners



hand grips



sillet exhaust
tips

BTW Product Catalog

TO ORDER CALL 520-789-7265 or go to "www.btw-trikers.org"

CAPS

BTW Flames Cap
Embroidered
Adjustable
Low Profile
\$12.00



BTW Skull Cap
\$8.00



BTW Military Cap
Adjustable
\$12.00



Available in Black or Beige

BTW mesh Cap
Adjustable
Embroidered
\$12.00



BTW FO3 Cap R/W/B
w/ eagle
low profile
adjustable



\$12.00

Cap Fon3 Flamed Mesh
w/eagle
Adjustable
\$12.00



TRIKE MOUNT

FLAGS & ACCESSORIES

3' x 5' SILK FLAGS



BTW Flag w/Staff Blk



BTW Flag w/Staff White



Flag BTW 3' x 5' \$20.00 Blk



Flag BTW Intl 3' x 5' \$20.00 White



USA flag w/Staff

All Trike Mount Flags including Staff \$12.00



BTW Intl flag w/Staff Blk



BTW Intl flag w/Staff White

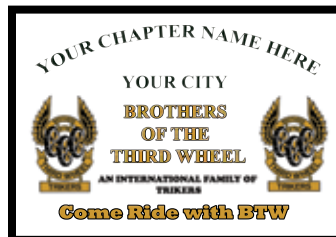

Custom Chapter Banner 3' X 5' \$55



Event Banner \$55.00 3' x 7' Standard or International logos

BTW Product Catalog

TO ORDER CALL 520-789-7265 or go to Store "www.btw-trikers.org"

ALL TANK TOPS & T-SHIRTS PRINTED ONE SIDE S - XL = \$17 2XL - 5XL = \$20

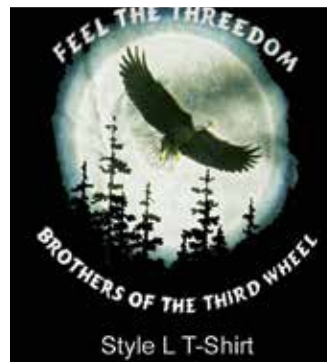

BTW Members will be able to go to the web site store and order any of the full line of SCW high quality gauges and receive their **25% Discount** off the current retail price. **Member must order through BTW to acquire this Whopping Discount.**

Marshall
INSTRUMENTS



SCX Full Sweep Performance Gauges
SCX full sweep gauges are value priced and feature the latest advances in gauge technology. All gauges feature white and amber LED through-the-dial lighting, red illuminated pointer, and easy-install wire harness and u-clamp.



BTW Product Catalog

TO ORDER CALL 520-789-7265 or go to "www.btw-trikers.org"

DENIM SHIRTS

Style W Denim
Mens long sleeve
w / pocket
Sizes: sm - 5X



Style WA Denim
Ladies - No Pocket
Sizes Small - 2X

**All Denim shirts
with embroidered
BTW logo
\$30.00**

Custom BTW Trophies:

SIZE 8" x 8 1/2" trophies are free standing or will hang on wall. The custom plate at the bottom is included with 2 lines of information for your event or activity. **Prices: \$25.00 ea.**

20% OFF if you buy 2 or More



Trike Parking Sign
9" x 13" metal \$13.00

NEW PRODUCTS



Long Sleeve -shirts
w/ Logo or Int Logo
Sizes:
S - XL \$20
2X - 5X \$25

BTW
Leather Key Fob \$3.00

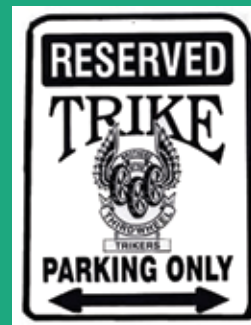

Style U Golf Shirt
w/Embroidered
Standard or Int Logo
Sizes: S -XL \$20
2X- 5X \$25

Pin Protectors
12 pk locking Pins
w/allen key \$7.00



NEW: CUSTOM TIKER
Gremlin Pewter Bell \$10.00



**ADD: Small Logo
to Front of T-Shirt
w/ large back
Logo**

add \$5.00



BTW Product Catalog

TO ORDER CALL 520-789-7265 or go to "www.btw-trikers.org"



\$10.00 EACH

BTW OVER 70 CLUB

BTW OVER 80 CLUB

BTW OVER 90 CLUB

BIG AL

Personalized Name Patch



Specify State

\$6.00 EACH

Standard LOGO Patch

International LOGO Patch



Standard or International
BTW LOGO PATCH

Large: 7.5" x 11.5" \$20.00
Medium: 5" x 8" \$15.00
Small: 2.5" x 4" \$10.00



BTW Product Catalog

TO ORDER CALL 520-789-7265 or go to "www.btw-trikers.org"



BTW Poster 16" x 20" \$5.00



BTW Decal Lg 8.5 x 12 \$15.00



BTW Bandana \$6.00



Bumper Sticker 3 for \$1.00



Coloring Book 2 for \$5.00

Triker MeOn3

Three Wheeler Tricentrum



PINS \$3.00 EACH



BTW Logo Pin \$5.00

| Item Description & Options (Color, Size, Etc.) | Price | Qty | Total |
|---|--------|-----|-------|
| Patch - Circle "Secretary" "Treasurer" "Secretary/Treasurer" "Road Captain" "Sgt At Arms" | \$1.00 | | |
| Patch - Circle "Ch Director" "Co-Ch Dir." "State Dir." "Co-State Dir." | \$1.00 | | |
| | \$ | | |
| | \$ | | |
| | \$ | | |
| | \$ | | |
| Specify Design # Shirt Color Size | \$ | | |
| Specify Design # Shirt Color Size | | | |

TODAYS DATE: _____

Total Amount _____

AZ Residents add 7%
 (Total Amount x .07 = tax)
 Shipping & Handling + 20%
 (Total Amount x .20 = S & H)

Note: Nothing Territorial (ie: Country, State, City, Region) may be worn on the Back of a Vest or Jacket. Chapter and State Patches are worn on the Front ONLY

Note: Overseas Orders will be Weighed, member will be notified of Shipping Costs and We will Wait for Verification to Send.

Total amount paid _____

Order Form: Mail With Check, Money Order or Credit Card Information To:
 (Out of USA orders - Credit Card Only)
 BROTHERS OF THE THIRD WHEEL
 P.O. BOX 2550 CORTARO, AZ 85652 USA

Print Name: _____ Address: _____

City _____ State: _____ Zip: _____

Method of payment: Check Money Order MasterCard Visa Discover

Credit Card#: _____ CVC # _____ Expiration: _____



Member Rides

THEY ARE ALL TRIKES
&
THEY ARE ALL WELCOME IN
BROTHERS OF THE THIRD WHEEL



NO MATTER WHAT STYLE OF TRIKE YOU RIDE , WHERE THE WHEELS ARE
OR IF IT HAS HANDLE BARS OR A WHEEL, OR HOW FANCY OR PLAIN IT IS,
IT IS STILL YOUR BABY AND IT IS YOURS TO ENJOY
AS LONG AS IT ENABLES YOU TO RIDE WITH ALL THE OTHERS,
IT IS AS GOOD AS THE NEXT

Member Rides

Peter Kozak's '96 HD with a Lehman conversion & his 2009 HD Trig-Glide both fantastic rides.



2017 BTW National Trike-In, Dodge City, Kansas Wright Park 1st Place - Doug Dummer's Home Built Trike

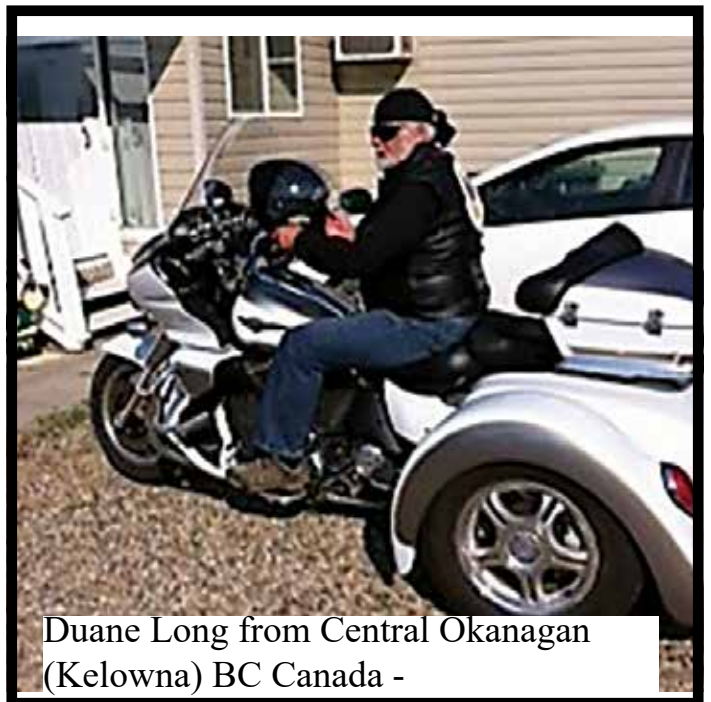

Duane Long from Central Okanagan (Kelowna) BC Canada -



"In Memory of Rosebud"

**REMEMBER! KEEP
SAVING THOSE TABS!**

Tabbs are used toward the purchase of medical equipment for Children's Hospital Wards. Also: Purchase a "Pull Tabs For Tots" patch for only \$5. This is a great looking red, white and black round patch with above picture on it. Money from sales is added to the tab fund. Send tabs and money for a patch to:

Stan "The Tabman" Demski
27705 Larchmont * St. Clair Shores, MI 48081

Member Rides



This JULY 10 2017 my wife & I celebrated our 40th Anniversary.
Here are photos of us then and now.

CONGRATULATIONS FROM BTW



FROM THE WEB

REBUILD OF A 1982 TRIDENT BY BTW MEMBER NOEL MOSS

This message thread is for documenting the rebuild of the 1982 Trident CX500-based police trike that I acquired this past spring. The first several postings below cover work during the past week.



THE TRIKE AS ACQUIRED

The first order of business is to get the engine running. The fuel system is a horror show - the tank is filled with stuff that belongs at an EPA toxic waste site. Really ugly. I am 100% confident that the carbs are a horror show as well. I had contacted Howard Halasz (a Randakk recommended carb guru for CX500 carbs) and he basically declined the carb work. If I don't find someone else to do the carbs I will take a shot at them myself although I prefer they be done by a carb guru.

First thing I did was to verify that the engine wasn't seized. I removed the spark plugs and the crankshaft access cover and was easily able to manually turn the engine over via the crankshaft bolt. The rubber boot on the right-side spark plug was dry rotted (most of the rubber pieces are dry rotted) to the point where water had accumulated in the spark plug recess. There is a boatload of corrosion in the recess. I blew out the accumulated crud and sprayed Kroil in there. After letting it sit awhile I was able to fairly easily remove the spark plug. There were a couple of small spots at the very top of the spark plug thread where there was a minute bit of aluminum from the head but close inspection showed the threads in the head looked pretty good. I was able to screw a new spark plug into the hole without any issues. The left side plug came out with no issues.

The work plan is as follows:

- 1) Clean the fuel system and rebuild the carbs.
- 2) Replace the throttle tube. The one that came on the trike literally crumbled.
- 3) Go through the electrical system sufficiently to get the starter and ignition working.
- 4) Change the coolant. Fix whatever leaks.
- 5) Change the air filter, oil and oil filter
- 6) Get the beast to fire up.

Once I get the engine running I will do several oil and filter changes followed by a cooling system flush and replacement of the coolant hoses.

7) Rebuild the brakes.

8) Go through the rest of the electrical system. This thing has a car battery rather than a bike battery. See the next post.

Stay tuned.

LEFT SIDE SPARK PLUG HOLE



RIGHT SIDE SPARK PLUG HOLE



RIGHT SIDE SPARK PLUG CAP



FROM THE WEB

For those of you who enjoy this type of unbelievable effort, patience and dedication to a challenge, go to the BTW web site at www.btw-trikers.org then to the Forum, then to the "TECH TALK & TIPS" look for the heading "Trident Police Trike - Rebuild Thread"

JUST A FEW OF THE PHOTOS FROM THE TOTAL STORY IN THE "TECH TALK & TIPS" ON OUR FORUM



IT'S ON THE ROAD
(But he is not finished, Great job Noel)

NOEL HAS OFFERED SOME HISTORY OF THIS TRIKE FOR US

The trike is a Trident police trike. It was built by a company named Municipal Industries which was located in Chicago and is no longer in business. Information I have found indicates that they built about 280 of these trikes for various police departments as well as private owners. A dealer named Regency in Chicago sold them as the MC-1 three-wheel motorcycle. Trident police trikes are not Harley Davidsons. They are based on the 1982 Honda CX500 motorcycle. The CX500 was Honda's first V-twin bike and it is a transverse V-twin, similar to a Motoguzzi. The engine is 500cc and has an early version of an electronic ignition. There are no points but by the same token, it is NOT a magneto ignition either. CX500s are water cooled and have shaft drive. MCI's modifications to the frame made it into a hardtail so the rear "suspension" is really a pair of small coilovers under the seat to cushion the rider's butt. The rear-end is from an early-70s Jeep CJ-5 and it uses Bendix brakes in the rear.

My particular trike was originally used by the St. Louis, Missouri Police Department. I acquired the trike from Howard "Crash" Telthorst, the Gateway chapter director in St. Louis. He had originally purchased the trike for his wife, Gay, but she apparently wasn't interested in riding it so it sat in his driveway for about 10 years before he sold it to me. I have reason to believe it's a "metermaid" trike due to its low gearing. It's geared so low that it's possible to start out in 2nd or 3rd gear with almost no clutch slip. At 45 - 50 MPH in 5th gear the engine is doing about 5500 RPM. At some time in the future I will see if it's possible to install taller gears in the rear-end to bring down the engine RPMs at speed. I have attached some additional images that may be of interest for the article.



Best regards...

Noel Moss

ANNOUNCING THE MC-1
THE NEW 3-WHEEL MOTORCYCLE WITH
INTEGRAL REVERSE GEAR

FULLY-EQUIPPED
READY-TO-GO!!



Call or Write for details:

REGENTRY LTD.
1001 N. W. 10th Ave.
MIAMI, FL 33136
Tel: (305) 571-1111
Fax: (305) 571-1112

EXCLUSIVE STANDARD
EQUIPMENT

- 510 cc. V-twin Engine
- 4-Speed Gearbox
- 4-Speed Reverse Gear
- 18" x 18" x 18" Wheel
- 18" x 18" x 18" Wheel
- 18" x 18" x 18" Wheel
- 18" x 18" x 18" Wheel

MC-1 LEASING AVAILABLE

whitcombhowry

BTW Event Flyers 2017



14th Annual KANSAS State Trike IN 2017

Sept, 15th, 16th & 17th

Community Building Garnett, KS

Friday: 4:30 pm Memorial Ride
 6:00 pm Cook Out (Hot Dogs with all the trimmings)
 7:00 pm Parkside Nursing Home Ride
 9:00 pm Run to Sonic/ Dairy Queen for Ice Cream

Saturday: 8:30 am Registration for Trike Show
 9:00 am Trike Show at the Community Building
 1:30 pm Event Run (Leaving from the Community Building)
 6:00 pm Saturday Night Meal
 7:30 pm State Meeting
 8:30pm Silent Auction & All Door Prizes

Sunday: 8:30 am Breakfast (continental)
 9:00 am Worship and say Happy Trails to You Until We Meet Again.

****Registration: \$20 each (Patch, Poker Hand for Meet the Officers & Saturday Evening Meal)**

T-Shirts Available Pre Order Only.
 Lodging: Economy Inn (785-448-6816) or Garnett Inn Suites (785-448-6800)
 Camping: North Lake (near event) (785-448-6816) or Garnett Inn Suits (785-448-6800)
 Contacts: Ray Scales 620-238-1844 ksbtwdir@gmail.com
 John Privett 785-248-3867 jprivett@sbcglobal.net

HIGH COUNTRY AREA BROTHERS OF THE THIRD WHEEL 13th ANNUAL BLOWOUT

TO BENEFIT CHILD HAVEN OF PRESCOTT & BTW NATIONAL
**REGISTRATION FEE: \$20 AT THE DOOR
 \$15.00 IF PRE-REGISTERED**
 (INCLUDES FUN RUN, DOOR PRIZE TICKET, PATCH AND SATURDAY MEAL)

SEPTEMBER 15TH – 17TH

Payson Campground & R.V. Resort
 808 E Highway 260
 For camping reservations, call 928-472-2267.

Majestic Mountain Inn
 602 E Highway 260
 For reservations, call (928) 474-0185 or (800) 408-2442
 Mention BTW and receive a discount at both places.

Friday:

9:00-10:30 – Registration @ Campground
2:00-3:30 – Registration @ Campground
 All day – Suggested rides in the beautiful pines.
6:00-8:00 – Meet & Greet – BYOB
 Early Bird door prizes

Saturday:

7:30-9:30 - Registration
10:00 – Fun Ride
2:30 – Group Events
5:00 - Awards & Dinner
6:00 – Entertainment

FOR MORE INFORMATION

CONTACT

Bill (Rackem) Magby – (928) 442-6310 KC Claassen – (928) 778-7020
 E-mail: evbrm01@gmail.com E-mail: kctriker@gmail.com

*"Being a leader of innovation and design,
 Torbleau Trikes builds you a worry free conversion
 Call us today for the trike of your dreams!"*



- **Trike Conversions for all Makes of Motorcycles**
- **Competitive Pricing**
- **Two Year, Unlimited Mile Warranty**
- **Custom Fabrication Available**

Phone: 608-873-0200
 501 Business Park Circle
 Stoughton, WI 53589

www.torbleautrikes.com
torbleautrikes@sbcglobal.net



TORBLEAU TRIKES, INC.



California State Fall Trike In Oct. 19th-22nd 2017

1850 W Cleveland Ave., Madera CA 93637
MADERA FAIRGROUNDS

Trike-In Cost: \$10 per person/Under 13 Free
Camping: \$15 per night **ALL 2,3, AND 4 WHEELERS WELCOME!**
Electricity: \$5 per night
RV's: \$20 per night

ALL TRIKES IN GAMES MUST HAVE CURRENT INSURANCE!

Fire Pitts must be 3 ft off of the ground! All Dogs must be kept on leash at all times!

**SUPER & HOTEL
 BTW DISCOUNTS
 JUST ASK!**

FRIDAY DAY RIDE

SATURDAY

Poker Run, Games, Trike Show, ? Race Truck, and You Pick-it Raffle

For more info contact

Loner Abbott: 559-781-8129 • lonerbtw@att.net

or

Margaret Winebrenner: 559-916-9037
margaret@suecorodino.net

BTW Event Flyers 2017Continued



2ND ANNUAL GATHERING

BROTHERS OF THE THIRD WHEEL

HOSTED BY THE CENTRAL AZ "SIDEWINDERS"

MONSTER TACO & CHILI BASH

SATURDAY - OCTOBER 28, 2017

11:00AM TO 5:00PM

@ 29362 N. VARNUM RD
SAN TAN VALLEY, AZ 85143

ALL YOU CAN EAT

TACOS & CHILI SODA & WATER

BEANS & RICE DESSERTS

\$15.00 PER COUPLE OR \$8.00 PER PERSON - PAY AT EVENT

AUCTION @ 3PM - 50/50 - PRIZES

PLEASE RSVP BY OCT 1 FOR MORE INFO

CONTACT: FLO SOUTHWORTH

TEXT @ 480-250-6952 OR LFSOUTHWORTH@Q.COM



ARKANAS STATE TRIKE RALLY 2017

October 12, 13 & 14

At the
Wanderlust Camp Ground
EUREKA SPRINGS AR

For camping call Wanderlust Camp Ground at 1-479-253-7385
Email at www.wanderlusttrv.com

Daily 50/50 drawings Door Prizes Rides

Friday Night HOT DOG ROAST

Saturday Night Door Prize Drawings & AR State Meeting

Event Patch \$5.00 To be sold at rally

For More Information

Contact

ARKANAS STATE DIRECTOR

Jimmy Anderson

1-501-388-1680 or 1-501-556-5872

Email address jajustlazy@gmail.com

BROTHERS of the THIRD WHEEL



17th Annual Turkey Fest

Nov 10th, 11th, 12th 2017 at Huachuca City/Whetstone, AZ

Featuring: The Award Winning Blue Grass Band Dusty River



50/50 raffles - Door Prizes Fri & Sat - Fun Runs - Games - Silent Auction

Hosted by: Southern AZ Smokin' Eagles and the Tucson Desert Renegades
All Proceeds go to: Charities of the Host Chapters & National

Where: Quail Ridge RV Resort-2207 N Yucca Dr. Huachuca City AZ 85616 (Hwy 82 & 90)
Email: info@QuailRidgeRV.com or call (520)456-9301 to reserve your spot
Full hookups & tent sites all \$16.00 a night (Mention 25% off with BTW)

Pre-register: at merclocke2@gmail.com with name & number in attendance

More Info: Dr. Lou Kaden (520)249-7410 or Desert Renegade Dir. Jack Martin (520)490-2403

Tuesday
8:00am Registration/Donation
10:00am Fun run to Tombstone
Afternoon open enjoy
Tomlison Tree Tryst
6:30-8:30 Dinner & Concert

Wednesday
8:00-7 Registration/Donation
8:00am Pancake breakfast/Donation
By Day Scott Brown 4:00
8:30 Blessing of the Trikes & Fun Races
TBA Band games, trick show, silent
auction & free time
4:30 Early Potluck Dinner

Sunday
8:00am & Coffee
Thank you and good bye

Save the Date

Brothers of the
Third Wheel

2018 Western Regional Trike-In

Riverside Resort and RV Park
Laughlin, Nevada
March 15-17, 2018

Activities are planned for the week
from March 11-17, 2018
St. Patrick's Day Pot Luck on March 17
Auction and Meeting Following Dinner

New rides and activities are planned. Save
the dates and join us for a week and/or
weekend of fun.

Registration forms and more information on
the events of the week will be forth coming.
jackregion9btw@dakotacom.net

FROM THE INDUSTRY

ELIO HAS JUST \$4,444 IN THE BANK WHICH DELAYS PRODUCTION AGAIN UNTIL LATE 2019



Things aren't looking too good....

by Javon Johnson , on August 21, 2017, 18:00

Surprise, surprise. The trail of broken promises that is Elio has once again decided to delay production. In a recent Securities and Exchange Commission filing, Elio has stated that production is not expected to begin until the fourth quarter of 2019 [1]. Come on, really, Elio? What kind of nonsense is this? Do you mean to tell us that it takes EIGHT YEARS to put a motorized tricycle into production? I mean, they raised MILLIONS of dollars through crowdfunding and other forms of investment [2], yet they have accumulated over \$145 MILLION [3] in debt without a single customer car being built.

If a company has received \$145 million in loans or financing or whatever, surely it's possible to produce ONE production car? I mean, Elio began toting around that they would build a \$6,800 car with 84 mpg [4], before realizing that this is quite a big ask. As a result, they effectively developed the Geo Metro-based engine after releasing the specifications, and to date, there is no EPA-approved mpg figure. Oh, and the price has been raised, again, to \$7,526 [5]. Furthermore, according to a SEC filing for the six-month period between December 31, 2016, to June 30, 2017, Elio had just \$4,444 in the bank. I don't know whether or not to laugh or cry at that figure. I honestly hope that that was a typo. I'm no accountant or financial analyst, but I think it takes more than four grand to run a car company. Unless Paul Elio was vigorously throwing money off of the Empire State Building, I can't imagine how funds were mismanaged that horribly to have such little money in the bank. This is absolute madness!

Classified ads are free for BTW members and run for 2 consecutive Issues if desired.
The Cost for non-Members is \$30 per Ad for 2 consecutive issues if desired.
Ads must be submitted by the 1st of the month prior to publication with required payment.

2016 Tryke by Fite-O-Customs



Fresh Chevy V8 (355 C. I.)
Edelbrock Aluminum Heads + Roller Cam
Johnson lifters and Harland Sharp Rockers
9.5:1 Compression
All double wall Tube Frame
.095 Chromoly Outer + .090 Mild Steel Inner
Fresh 700R4 Trans
Fresh 10 Bolt Open Differential (2:73 Gears)
Moser Axles
Springer Front End by American Suspension
Asking \$ 25,000 OBO
Trailer \$3,000 OBO
MUST SELL
(619) 760 - 7333



continued...

Classifieds

Custom Harley Trike '82 Shovelhead. A Six Shooter rear end kit professionally mounted on a new swing arm, . Runs Great! Tires P295/50R-15 on new chrome wheels. New fenders. less than 50 miles on new top & new clutch by Harley Shop. New top end not broken in yet, so cannot be ridden home, I will assist in shipping, your cost. Always garage kept in winter, covered when not ridden. Never been down, shows normal wear. I hate to part with her, but broken neck forced me to give up riding.

\$7,500.00. look at the photos and you will agree this is a great bike for the money. questions call Cliff Young 801-931-9241 or email cliffy1950@hotmail.com



VW Trike - Engine rebuilt, dual Weber 32 carbs, side by side seating, tiller bar steering. All steel frame completely rebuilt. New axels, paint and lights. I have enjoyed for years and now it is time for someone else to enjoy. Asking \$8,000.00 or best offer. Contact - Eugene "Mike" Mielke - 507-398-9955 3405 S Tomahawk Rd Lot 131, Apache Junction, AZ 85119



2012 type III. VW Trike 1600dp fresh Motor From a 71 Square Back Full- automatic transmission, all metal body three wheel disc brakes, long FXP front end. Turn signals front & rear Maltese cross tail lights. Z Bars weighted down front end 21" front wheel only 500 miles on trike, 8 gallon aluminum tank a fast, fun ride with buckets seats, Harley running boards, very comfortable. Garage kept located in Rockaway Beach Oregon call 503 812 4041 Animal \$6,500



White trike is registered as a 1978, It is 1681 cc dual port. Brand new tires & chrome wheels. Runs perfect. Both trikes have new wide glide front ends. The bare trike is 2004 FXD front frame with gas tank with gauge. Springer front end, Harley Davidson trunk, and a number of parts, two aluminum fuel tanks and a number of assorted parts. Contact; Al @ 702-281-3075. Everything must go. Asking \$7000.00.

PREMIER TRIKES

10329 EAST 101ST STREET NORTH
VALLEY CENTER, KANSAS

WWW.PREMIERTRIKES.COM
(316) 744-2841



CUSTOM BUILT TRIKES, FRAMES, FORKS, & MORE. CHECK OUT OUR WEBSITE AS WE ARE DAILY ADDING TO OUR PARTS CATALOG.

LASER CUT PARTS:

- HEADER FLANGE
- BRAKE & CLUTCH PEDALS
- MASTER CYLINDER MOUNTING PLATES
- DIFFERENTIAL SUSPENSION PARTS



FIBERGLASS PARTS:

- ROADSTAR BODY
 - OPTIONAL SEALED TRUNK
- ROADSTAR GRILL
- TUNNEL COVER
- FRONT FENDER 5" OR 6"
- REAR FENDER 7" OR 10"
- AIR SCOOP



GAUGE POD

PREMIER AIRIDE FORK

CUSTOM TRIKE FRAMES

PLUS MANY MORE PARTS AVAILABLE

continued...

Classifieds

1986 Honda Goldwing 1200CC
 new tires, new battery, new alternator, set-up/spare belt, Spare Motor with 30,000 miles, Spare Floor boards, Spare side plates, Water pump, new seat, Radio, Motor reworked 2000 miles ago, cup holders front and back, arm rest, speakers on trunk, headsets for helmets, 2 sets of helmets, 1986 Tool Set, 2 repair manuals, Voyager set up to make a trike with Chrome Wheels asking \$7000.00 or best offer Contact Darryl at 352 638 3554 if no answer please leave message



For Sale: 2007 Trike Shop Road Hawk 1800 VW automatic trans. 105 Hp. Headers and dual Webber carbs. Garage kept one owner(lady) 18,000 miles, excellent condition!! Comes with 2003 Bush-Teck trailer, \$19,500 w/ trailer Thanks!!! Paula at 308-760-0470. NE

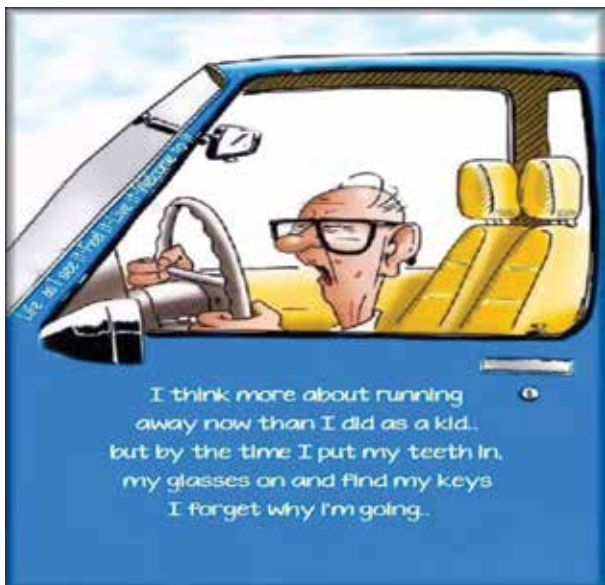

2012 Harley Trike. 51 miles (Yes 51 miles) \$25,000 OBO Health issues causing sale.. Joe/Cheryl 307-686-2819 WY LAMONTE@BRESNAN.NET

Classifieds

continued...

2011 HARLEY DAVIDSON TRIKE – Tri Glide Ultra Classic FLHTCUTG – Excellent Condition!! Meticulously Maintained & HD Dealer Serviced! Always Garaged & Covered– Only 16,000 miles Engine: 103 cu in, Transmission: 6-Speed, Color: Cool Blue Pearl / Vivid Black, Gas Tank Capacity: 6 Gallons
Brakes: ABS, Parking Brake, Electric Reverse, AM/FM Radio & CD Player, Luggage: Huge Rear Trunk & Tour Pack with additional Top Rack, 2 Front Glove Compartments, Super Comfortable Wide & Cushy Touring Seating for both Driver & Passenger with Full Passenger Wrap-Around Back Rest w/Rear Speakers
THE EXTRAS – Plus Over \$3600- in Custom Additions
CONTACT: Barbara or Robert (408) 887-0388 OR (408) 656-1107 calls or voice messages **\$21,900**



2004 Honda 1800 Trike, 13,339 miles, Champion Kit, asking \$18,000 OBO, Phone: 918-255-6411

2006 Custom Built Trike: 350 Chevy eng. Aluminium Heads & Intake, Turbo 350 Trans. 9" Ford rear end, 4link suspension, new Quadra Jet carb & more. Really Sharp! 5100 mi. \$18,995 OBO 715-662-2753



FROM THE MEMBERS

“Tree Of Life”

There were a lot of cool places I could “hang out” on our 365 acre farm growing up. We had two springs, a 3 acre pond and a swamp back in the big woods. There was a stream that ran through the whole property and at least 5 wooded lots with different trees, vegetation and wildlife. It was a mecca of beauty, solitude and solace. There was, however one secluded spot that made me feel like I was on top of the world, master of my domain and king of my own little realm.

When we moved to Union County, Ohio in 1957 I was devastated, I had left the only home and friends I had ever known for a region that I was unfamiliar with. I always felt at home in the out doors and especially in the woods, so I imagine that is why I sought a safe haven up along the wooded creek bank across the road. There was an old Oak tree that was about 3 foot in diameter when I first discovered it at 8 years old. I was totally unaware of how old it was but I didn’t care. It had room to sit between it and the steep bank that dropped well over 20 feet down to “Buck Run Creek” and it sustained much life within it’s system. Squirrels had many nests in the tall limbs that rose above the creek bank. Raccoon’s were housed in a couple of the bigger branches that were hollow from lightening strikes killing the limbs. Different species of birds nested in the foliage of the limbs in the spring. The roots were mined with Ground Hog holes and loose dirt piled over the edge. At some time a previous landowner had built a lean-to and attached it to the old tree but time had all but destroyed it, leaving 2 steel posts that gave the structure it’s strength. For years I rode my horse by the tree 2 times daily, herding the Holsteins to our barn for milking. The cattle wore a deep, wide path down the bank and crossed the creek at the shallows.

From that vantage point you could see my parents house, 600 yards across the creek and the valley of rich topsoil. West of my parents house was a little road where you could observe people coming to a screeching halt, they didn’t remember the stop sign until they crested the hill. On the same side of the road, another 250 yards was “Buck Run Cemetery” where the newest grave marker dated back to 1947. Just beyond that was “Buck Run Bridge”, where once stood an old covered bridge which had many of it’s own memories through time. Looking east you could see the farm houses for miles, heading into town. It was from under that tree I sat and hunted, camped as a child and as an adult with my own children. After hot summer days of baling hay or shoveling dusty grain into bins, I would take a much needed dip in the cool stream, guarded by the shade from that tree. I sat there many times and thought about my future plans and the war in southeast Asia. I built my house not far from the old tree. My sons and I watched many deer, fox, coyote and other wild animals drink from the waters flowing under the tree. It was a majestic place to relax, ponder thoughts and reflect back on some sad events in my life.

I shall never forget the crisp, still, cold January morning I sat quietly with a muzzle loader hunting Deer. I heard the emergency squad sirens blaring as they came from the Allen Center Station, 2 mile away. I watched them turn the corner and stop in front of my Mom and Dad’s house. I hustled over in time to watch the EMT’s load mother into the ambulance for her last trip to town from a fatal stroke. I remember the warm November afternoon when I shot the prettiest buck I had ever seen on that land only to loose his trail, finding him 3 days later, mangled and ripped from coyote and other predators. The auto accident I witnessed as a ‘57 Chevy couldn’t get stopped and rolled across the road killing one person and injuring 3 other family members. At times I would take a break from field work for a cool drink from my thermos under the tree. There I observed my friends riding their BSA, Triumph, Norton, Honda and Harley Motorcycles up and down St. Rt. 245. I longed to be riding with them but the work had to be done. Back then I would see an occasional Trike and wondered how it rode and drove. I wept under that tree as I readied for my move from the house I built and living 50 years on that property. My health kept me from living there,

FROM THE MEMBERS

Continued:

I could no longer care for all the acreage, water ways or keep up with taxes and insurance. My best years were behind me, as were the tree's. My old steel chair remains for my frequent visits. I still observe Motorcycles and many Trikes traveling on St. Rt. 245.

The most saddening delima is for the tree itself. Erosion from all the freezing and thawing, high water from the creek and rains washing down the old cow paths has caused the earth to fade away. The grand old tree has subsided down the bank by over 3 feet. The roots are all out of the ground and mostly dead. The limbs are dying and falling off, lack of nutrients and water have taken a toll. Lightening has hit it many times and there are no animals inhabiting its structure. The strong old Oak is at it's end and will soon fall into the stream that was once it's life's blood. My son will then saw it up for firewood to assist with his winter heat.

It takes a lifetime to grow a tree. That tree is as much a part of me as my family. It was my friend and confidant. Man also grows old and weather's through each passing season. We feel our weak and eroded systems breaking down and slowly decaying from with-in. We leave our family and friends and become a memory in time. As the old Oak has sprouted many new saplings we too leave sons and daughters to carry on our legacy and family name. The tree of life will always sustain, in one way or another and so will we. **Geno BTW**

ask about special Pricing for BTW members



AMSOIL

The First in Synthetics

Speed Adams
INDEPENDENT DEALER

Outwest Synthetics

1604 Boise Ave
Gillette WY 82716
307-231-0057
twincam1951@gmail.com
<http://outwestsynthetics.myamsoil.com>



**PREMIUM SYNTHETIC
MOTOR OIL FOR
ANY ENGINE**



The First in Synthetics

SYNTHETIC SOLUTIONS

Continued

FROM THE MEMBERS

Iowa, a place to grow!

Home at last. After some of the hottest rides in history! Leaving Sioux City, Iowa on a Monday, with temps at some very pleasant levels, we rode south on the Nebraska side of the river. It wasn't long and the temp began to climb and climb and finally stopped climbing at 102* with 111* heat index! Enough! We stopped in Salina, KS, for the night. We continued the next morning, with much the same scenario. Landing in Dodge City, about 1:30pm and 98*. Again, we were drenched in sweat! None the less, there were new friends to make, things to do and see. We checked in and went about our tasks. The next few days, found us visiting, riding, visiting more, riding more and eating till we almost burst at the seams! But what more could we have asked for, than to be with good friends, good food and doing what we all love doing, visiting and riding! Our thanks to Alex and the entire BTW crew, for a job well done. It is quite a chore to put together a major reunion such as this, involving long days and a ton of worrying! That time is over and the preparation for next year is now beginning! Again, we from the SiouxLand Trikers, thank you all, very much for your hard work, for our benefit. Our thoughts and prayers are with all of BTW members. Be safe, ride safe!

SiouxLand Trikers



STAR THE PUPPY THAT WON EVERYONES HEART AT THE NATIONAL TRIKE-IN

From Mom

Star really enjoyed the Central States Rally in Harrison Arkansas, and has a ride for the Rally in Dodge City. in July.

FROM THE MEMBERS

Continued



CHECK 5 BEFORE YOU RIDE

1: Tires, check your tires to make sure they are properly inflated. Every rider should know the proper PSI rating for their tires. Checking them when they are cold is best. Check them for any wear, anything embedded, broken or damaged spokes and rims, and make sure the tread is adequate.

2: Lights, Make sure all lights are in good working order. Head lights (High and Low Beam), Brake lights and Turn Signals. Check that the covers are not loose or cracked, are free of dirt and bugs, and that the bulbs are bright enough to be seen. (Always carry extra fuses.)

3: Controls. Make sure your cables are in good condition, not worn or frayed, no kinks or bends, and are securely connected. Check your clutch and brake levers, make sure they are not loose, that they pull easily and return to their proper position. Look at your brake and shifter, make sure they are attached securely, not bent, and in proper working order. Double Check Your Brakes.

4: Fluids. Check your fluids, make sure your oil level is sufficient. Improper oil level could damage your bike. Everyone should know their bikes correct oil weight, and how to check and fill it properly. Check your gas, you may have used more or forgotten to fill up after your last ride. Your boots are not made for walking.

5: Kickstand. Check that it is properly attached, not loose, wobbly or bent. You don't want to be riding down the road, look in your mirror, and see your kickstand bouncing down the road behind you.

The goal is to enjoy the ride and arrive safely.

NEW BENEFITS FOR MEMBERS

Accidents don't happen on a timeline. AMCN Fly-U-Home has you covered.

An annual AMCN Fly-U-Home membership can cost only \$149 per year for your entire household.

Should you become hospitalized as an inpatient more than 150 nautical miles from home, AMCN Fly-U-Home will provide you with air medical transportation bedside-to-bedside to the hospital of your choice near your home. Both sending and receiving hospitals must be in the Contiguous 48 States.

AMCN Fly-U-Home provides access to medical referrals, consultation, and prescription assistance. This program connects members 24 hours a day, seven days a week, to the resources of AMCN Fly-U-Home. Members have access to AMCN Fly-U-Home's Logistics Center for information about how and where to obtain medical care while at home or while traveling, including medical monitoring and coordination with local health care professionals.

QuickFacts

- ✈ We have more experience than anyone in the business
- ✈ We have completed more than 18,000 missions since being founded more than 30 years ago
- ✈ We own and operate more than 35 aircraft strategically positioned around the United States
- ✈ We don't rely on broker services, who aren't ultimately responsible for transporting you
- ✈ Our clinical capabilities are bar none
- ✈ We have nurses and paramedics on call, specially trained for these transports
- ✈ Our product is exceptionally priced: Competitors charge \$300+ a year for membership



For more information:
877-238-0010
www.airmed.com/Fly-U-Home

NEW BENEFITS FOR MEMBERS



Membership Application - Brothers of the Third Wheel Arkansas Chapter

By applying for membership, I agree to AirMedCare Network's terms and conditions on the bottom of this application.

SIGN OR INITIAL HERE

TODAY'S DATE

/ /

STEP 1: MEMBER CONTACT INFORMATION

| | | | | | |
|--|-----------|---------------|-----|---|---|
| First Name | Last Name | Date of Birth | | Home Phone | Cell Phone |
| Physical Address | City | State | Zip | County | Do you live within the city limits? <input type="radio"/> Yes <input type="radio"/> No |
| Mailing Address (if different from left) | City | State | Zip | E-Mail * In order to sign up with recurring payment options, you must provide a valid email address | |

STEP 2: LIST ADDITIONAL MEMBERS IN HOUSEHOLD

| | | |
|------------|-----------|---------------|
| First Name | Last Name | Date of Birth |
| First Name | Last Name | Date of Birth |
| First Name | Last Name | Date of Birth |
| First Name | Last Name | Date of Birth |
| First Name | Last Name | Date of Birth |

STEP 3: CHOOSE YOUR MEMBERSHIP OPTION(S)

| | | | |
|---------------------------------------|------------------|--------|-----------------------|
| Platinum (25 Year) Membership* | Entire Household | \$1125 | <input type="radio"/> |
| 10-Year Membership* | Entire Household | \$550 | <input type="radio"/> |
| 5-Year Membership* | Entire Household | \$275 | <input type="radio"/> |
| 3-Year Membership* | Entire Household | \$165 | <input type="radio"/> |
| 1-Year Membership | Entire Household | \$55 | <input type="radio"/> |

*Multi-year memberships are not available in Indiana or California

STEP 4: SET UP YOUR PAYMENT PLAN

PAYMENT OPTIONS (select one)

- Check or money order. Make payable to: AirMedCare Network
- One time credit card payment or automatic transfer from checking account.

BANK INFORMATION (for check funds transfer)

Name on bank account _____
 Routing number _____ Account number (please attach a voided check) _____

CREDIT CARD INFORMATION

Credit Card Number _____ Expiration Date _____

Signature _____ 3 digit code on back of card
4 digit code on front for AMEX

Statement of Authorization I authorize AirMedCare Network to initiate the EFT withdrawal as indicated above. If I have elected to pay by credit card, I agree to abide by all terms and conditions of my credit card agreement. If I have elected to pay via EFT, I authorize my financial institution to transfer the amount indicated on the attached voided check to AirMedCare Network. Adjusting entries to correct errors are also authorized. It is agreed that these debits and adjustments will be made electronically and under the rules of the National Automated Clearing House Association (NACHA). This authorization is to remain in full force and effect until written notification is given to the AirMedCare network of its termination.

(Signature required) _____ Month / Day / Year

Questions?

Call 800-793-0010
or visit www.amcnrep.com

| | | | |
|---------------------|----------|------------|-----------|
| For Office Use Only | GET CODE | TRACK CODE | PLAN CODE |
| | | | 12914 |

AMCN Membership Terms and Conditions

AirMedCare Network is an alliance of affiliated air ambulance providers* (each a "Company"). An AirMedCare Network membership automatically enrolls you as a member in each Company's membership program. Membership ensures the patient will have no out-of-pocket flight expenses if flown by a Company by providing prepaid protection against a Company's air ambulance costs that are not covered by a member's insurance or other benefits or third party responsibility, subject to the following terms and conditions:

- Patient transport will be to the closest appropriate medical facility for medical conditions that are deemed by AMCN Provider attending medical professionals to be life- or limb-threatening, or that could lead to permanent disability, and which require emergency air ambulance transport. A patient's medical condition, not membership status, will dictate whether or not air transportation is appropriate and required. Under all circumstances, an AMCN Provider retains the sole right and responsibility to determine whether or not a patient is flown.
- AMCN Provider air ambulance services may not be available when requested due to factors beyond its control, such as use of the appropriate aircraft by another patient or other circumstances governed by operational requirements or restrictions including, but not limited to, equipment manufacturer limitations,

governmental regulations, maintenance requirements, patient condition, age or size, or weather conditions. FAA restrictions prohibit most AMCN Provider aircraft from flying in inclement weather conditions. The primary determinant of whether to accept a flight is always the safety of the patient and medical flight crews. Emergent ground ambulance transport of a member by an AMCN Provider will be covered under the same terms and conditions.

- Members who have insurance or other benefits, or third party responsibility claims, that cover the cost of ambulance services are financially liable for the cost of AMCN Provider services up to the limit of any such available coverage. In return for payment of the membership fee, the AMCN Provider will consider its air ambulance costs that are not covered by any insurance, benefits or third party responsibility available to the member to have been fully prepaid. The AMCN Provider reserves the right to bill directly any appropriate insurance, benefits provider or third party for services rendered, and members authorize their insurers, benefits providers and responsible third parties to pay any covered amounts directly to the AMCN Provider. Members agree to remit to the AMCN Provider any payment received from insurance or benefit providers or any third party for air medical services provided by the AMCN Provider, not to exceed regular charges. Neither the Company nor AirMedCare

Network is an insurance company. Membership is not an insurance policy and cannot be considered as a secondary insurance coverage or a supplement to any insurance coverage. Neither the Company nor AirMedCare Network will be responsible for payment for services provided by another ambulance service.

- Membership starts 15 days after the Company receives a complete application with full payment; however, the waiting period will be waived for unforeseen events occurring during such time. Members must be natural persons. Memberships are non-refundable and non-transferable.
- Some state laws prohibit Medicaid beneficiaries from being offered membership or being accepted into membership programs. By applying, members certify to the Company that they are not Medicaid beneficiaries.
- These terms and conditions supersede all previous terms and conditions between a member and the Company or AirMedCare Network, including any other writings, or verbal representations, relating to the terms and conditions of membership.

*Air Evac EMS, Inc. / Med-Trans Corporation / REACH Air Medical Services, LLC — These terms and conditions apply to all AirMedCare Network participating provider membership programs, regardless of which participating provider transports you.

THE 2017 BTW NA IN DODGE



TRIKE CENTRAL & BANQUET



BTW presenting a \$1,000 Donation to CASA-Children Worth Saving

Our hard core BTW members watching Disney's MOANA

Normally I get Arrested and/or Hung at these events. This time they made me a Drover (They said it was a good thing?)



NATIONAL TRIKE-IN DODGE CITY KS



LIGHT PARADE



VETERANS SERVICE W/THE HONOR GUARD AT THE 9/11 MEMORIAL AND BLESSING OF THE TRIKES

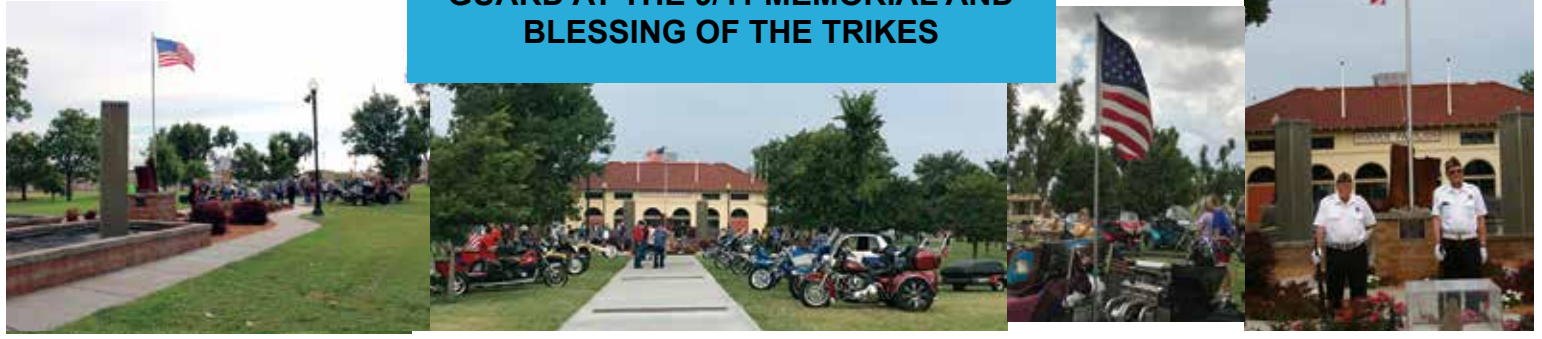

VISIT TO VETERAN HOME AT FORT DODGE



THE 2017 BTW NA in DODGE



INTERNATIONAL TRIKE-IN TOPEKA CITY KS



TRIKE RIDES



TRIKE SHOW





News From Around the World on Trikes

NORTH AMERICA

Central Ohio Trike Riders. Three generations of trikers. Trikes from left to right, Jim Seymour and Melissa Russell-Seymour, Russ Russell, Russ Jr, and Cody Russell. Family who loves to ride together.



Siouxland Trikers - This trip included a "Freedom Rock", A large painted rock done up in a patriotic theme. There will be 99 of them in Iowa within a few years, one in every county. just a little FYI from Iowa. Thanks, Don from Siouxland Trikers of Sioux City Iowa



Siouxland Trikers July meeting- ride by Siouxland Trikers of Sioux City Iowa

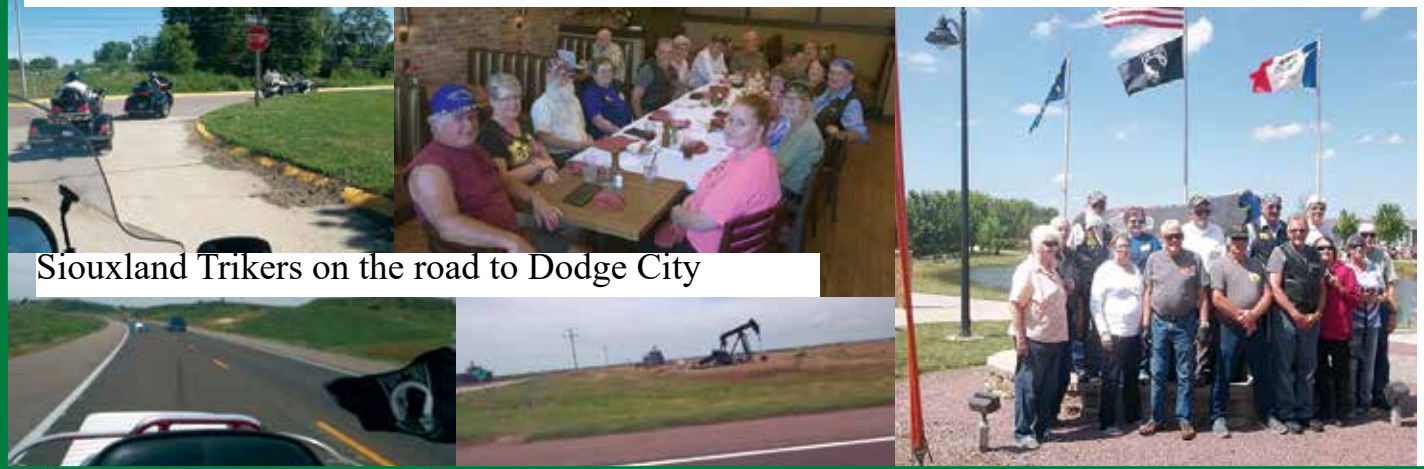

Siouxland Trikers on the road to Dodge City

...continued

News from Around the World on Trikes

Iowa Tripod Trikers at Ruthven Days Parade



Iowa Tripod Trikers at Grotto of the Redemption West Bend, IA



Iowa Tripods Trikers Trike-In Blackhawk Lake, IA



Iowa's Tripod Trikers at Everlys Leather Shoppe bike/trike show and charity ride.



News from Around the World on Trikes

...continued

Andrea, Eugene, Michele on her ride to Yosemite from Tadera in May



Eugene, Michele, Andrea, Big Cam, Cher, Scout, And General



General and Andrea at Royal Aces BBQ

Scout and General at Royal Aces BBQ



Cowboy with Evelyn from E. Central Kansas



Jay and Evelyn Kimes at National Trike-In



Group of Southern AZ Smoking Eagles



Hello to All, Summer has hit the South West with a vengeance and the Monsoon Rains finally arrived. We did get some rides in before the heat of the day Had a great 4th of July parade with our members riding and decorating our trikes & of course the candy all the kids wait for along the parade route. Then on to a potluck breakfast at Eric & Tracy's house. Had 2 more rides between the rains Hot Rods for lunch in Tucson, always a good time there. Then onto the Garlic Festival the following weekend at the Triangle T. good for some great home grown garlic & of course there's nothing like Garlic Breath..LOL The plans are in the works for the 17th Annual Turkey Fest coming up the week end of Nov 10th, 11th and 12th. Hope to see a lot of you there. Ride Safe, Free and God Bless

Iowa State BTW members and Iowa Heartland Trikers members at Iowa Tripods Trike-In at Blackhawk Lake



...continued

News from Around the World on Trikes



BTW-Coastal Cruisers- Group at the Zoo, sign describing the cougar statue, Linda Edwards, Terry Edwards, Ron Yeager & Lisa Yeager (from North Sound Threedom Riders) Terry Edward & Churchy with Gorilla statue, Terry Edwards with the Alligator statue A65-A67- BTW-Coastal Cruisers then real zoo animals – Lama, Parrots & Reindeer, Joanne & Rusty Pitts trying to eat one of their GIANT entrees – Chili Dog, Lisa & Ron Yeager, trikes parked at the drive-in, Ron & Lisa Yeager by their trike, Linda & Terry Edwards by their trike, Trikes riding to Roger & Kathy Miller's, Linda Lu Churchward feeding Lisa Yeager, Kathy Miller with great granddaughter, the guys -Roger Miller, Terry Edwards, Jerry Curtis & Gary Nuttbrook, pies, ice cream, lemonade & Tea. A fabulous way to end a ride – dessert with our hosts Roger & Kathy Miller.

Continued

News from Around the World on Trikes

Iowa State BTW members and Iowa Heartland Trikers members at airport checking out B17



Iowa state BTW members and Iowa Heartland Trikers members at Newton Bike Night



Motorcycle Accident?

OVER \$200 MILLION RECOVERED FOR OUR CLIENTS

Law Offices of

Richard M. Lester

Founder, Aid to Injured Motorcyclists

24 Hours - Toll Free (800) 531-2424
(800) ON-A-BIKE

We are endorsed by the National Coalition of Motorcyclists and more than 2000 motorcycle groups throughout the United States and Canada, and serve as Legal Counsel for the Confederations of Clubs.

- 110 Offices Throughout North America
- Free Legal Consultation
- No Recovery = No Fee
- We Make House Calls
- Attorneys in Every State & Providence Who Ride
- No Fees on Motorcycle Damage Recovered
- Also Auto Accidents



RECIPIENT OF THE FREEDOM FIGHTER AWARD

AIM 4832



IPHONE/ANDROID USERS SCAN TO DOWNLOAD OUR NEW SMARTPHONE/APP

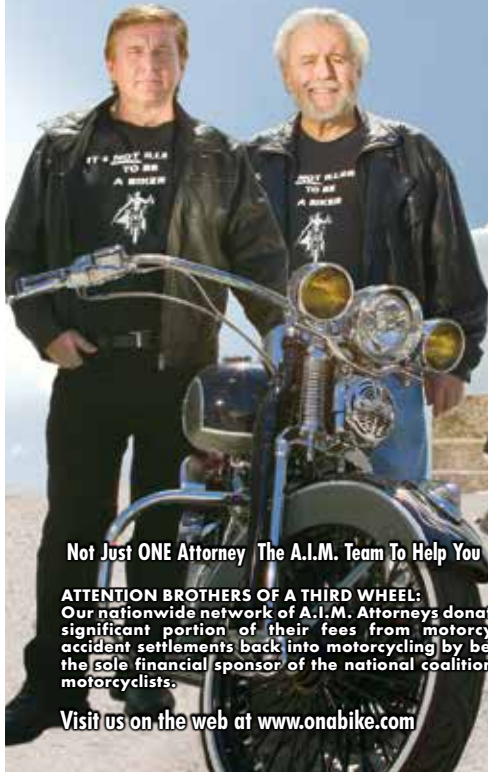

Not Just ONE Attorney The A.I.M. Team To Help You

ATTENTION BROTHERS OF A THIRD WHEEL: Our nationwide network of A.I.M. Attorneys donate a significant portion of their fees from motorcycle accident settlements back into motorcycling by being the sole financial sponsor of the national coalition of motorcyclists.

Visit us on the web at www.onabike.com



News from Around the World on Trikes

Continued



Central Valley Chapter BTW has been busy; many rides this summer! Attended American Legion Western Romp on the coast, Oroville Rally and trips around the valley. Mikes new trike is done and on the road! Designed and built by Ken Mohn, one of our road captains! New members Skip and Lucy trike has amazing paint! Looking forward to fall weather !!

...continued

News from Around the World on Trikes



BTW Trikers Iowa Chad and Bob at Backroads Biker Leather Shoppe Bike/Trike Show and Shayla Bee Charity Ride



SN Spyder Riders



On Saturday some of our members attended the Yellowjackets MC Bike Show, and we are happy to announce we took all three places in the trike class. First place went to Pat Douglas, Second place went to Ernest Weick, and Third place to Dave and Ronda Clay Fulks, congratulations to our winners!!!



News from Around the World on Trikes continued

LONG BEACH CRUISER - BTW
OUR ROAD TRIP TO VENTURA

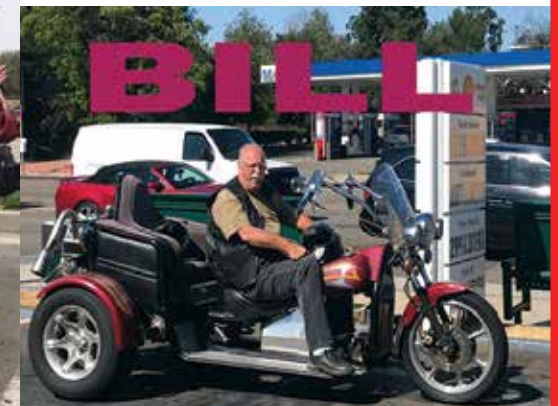

News from Around the World on Trikes

CALIFORNIA STATE SPRING TRIKE-IN



News from Around the World on Trikes

Continued

CALIFORNIA STATE SPRING TRIKE-IN



News from Around the World on Trikes **SWEDEN**





News from Around the World on Trikes **BTW FRANCE**



Notre Secrétaire Philippe Guérende à la Bayeux. Signe particulier : toujours sourire, toujours zen et attitude positive ! Belle retraite à vous, jeune retraité!



MON ASSOCIATION
PAR ANNICK MOSSAZ ET MUGUETTE BERMENT

« Une sensation de liberté »

GILLES LIETTI préside l'association BTW-France qui rassemble sur toute la France plus de 200 équipages de trike, des trois roues. En septembre, ils se réuniront lors d'un meeting international en Italie.

Qu'est-ce qu'un trike et depuis quand êtes-vous triker ?
Gilles Lietti : C'est une passion que j'ai depuis tout petit. Ce véhicule arrive des États-Unis, développé par d'anciens aviateurs revenant de la guerre du Vietnam. Manipulés, ils ont fabriqué leur moto et cela donne cet engin qui m'a été honoré en France en 1999. Enfant, j'allais souvent dans le sud de la France et je voyais des Allemands avec ce type d'engin. Quand ils les faisaient tourner, j'étais en admiration devant ces véhicules. Et j'ai craqué voilà sept ans.

Que ressentez-vous sur cet engin ?
G.L. Une sensation de liberté, comme sur une moto car moi avec un guidon entre les mains, le vent ou la pluie sur le visage. Mais j'en ai senti beaucoup plus en sécurité car j'en vais à pleins, sans appréhension de partir sur une flaque d'huile dans un virage. Par contre, nous sommes positionnés assez bas, à ras du sol. Certaines retrouvent les sensations du karting.

Quels souvenirs avez-vous gardés avec votre trike ?
G.L. J'en ai beaucoup, notamment lors de la découverte de villes par les personnes handicapées. Quand elles arrivent devant nos incroyables machines avec leur sourire et leurs larmes, leur excitation spontanée m'apporte mes premières sensations. Quand j'ai le spleen, je profite à ces merveilleux moments. Cela suffit à illuminer ma journée.

Président : Gilles Lietti
Date de création : novembre 2013
Adhérents : 200 équipages
Contact : 23100 Aizles-Bains
Tel. 03 83 33 33 33

« J'ai craqué pour un trike il y a sept ans... »



Nous arrivons à Verdun



installation terminé !
manque que le soleil



...continued

News from Around the World on Trikes **BTW FRANCE**



Ava, Missouri

Possum Pride Trike Bodies

possumpridetrikebodies.com

417.683.5773 • info@possumpridetrikebodies.com

ITEMS OF INTEREST

BTW's TOP 3 FOR NEW MEMBERSHIPS

USA

CANADA

INTERNATIONAL

1st Place

OH

UK

2nd Place

WA

FRANCE

3rd Place

KS

ATTENTION ALL MEMBERS

**KEEP THE PHOTOS OF YOUR TRIKES AND
ARTICLES ABOUT YOUR TRIPS COMING!
IF WE DON'T FIND ROOM THIS TIME WE WILL
GET THEM IN THE NEXT ISSUE.**

Please try to keep the photos at 150 pixels or more for better pictures in the Magazine THANKS

PLEASE NOTIFY HEADQUARTERS OF:

CHANGE OF ADDRESS, PHONE

& ESPECIALLY E-MAIL ADDRESS

WE WANT TO KEEP YOU INFORMED OF THINGS AS SOON AS POSSIBLE.
(Correcting your email on the web site does not CHANGE
your information at the office)

Notice: A copy of all the Financial Reports are now available to all current members and they can be found on the web site.

ITEMS OF INTEREST

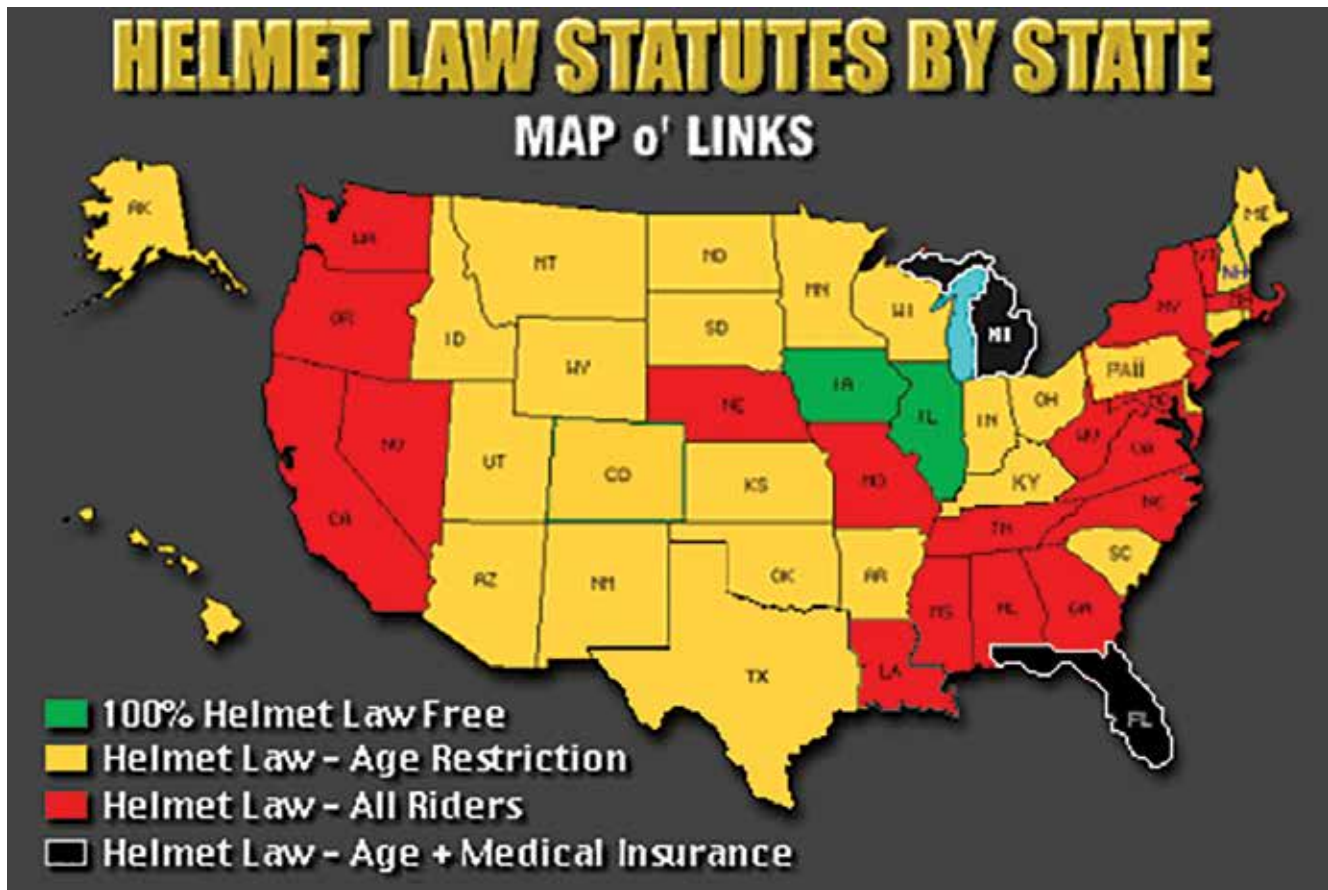

TIPS ON PHOTOS FOR THE MAGAZINE

IF YOU TAKE PHOTOS WITH YOUR PHONE AND IT IS SET AT 72 PIXELS IT IS THE LOWEST QUALITY OF PICTURE THAT THE PHONE PRODUCES. MOST PHONES CAN BE SET TO A GREATER PIXEL OUTPUT.

EACH PHONE SETTING IS DIFFERENT, HOWEVER YOUR SERVICE PROVIDER CAN HELP WITH HOW THAT IS DONE. A SETTING OF 150 PIXELS IS GOOD AND 200 PIXELS WILL GIVE YOU A BEAUTIFUL PHOTO, THAT WILL NOT BE GRAINY AND THE COLORS WILL BE TRUE AND SHARP. PHOTOS THAT WE RECEIVE AT HQ IN 72 PIXELS ARE RUN THROUGH A PROGRAM TO CLEAN THEM UP BUT NOT MUCH HAPPENS AS THE BASE IS SO LOW THAT THE PROGRAM CAN ONLY LIGHTEN OR DARKEN THEM. THIS IS JUST A TIP SO WE CAN POST BETTER PICTURES IN THE MAGAZINE TO MAKE YOUR TRIKE LOOK ITS BEST AND OF COURSE YOU AS WELL. HOWEVER IN MY CASE IT WOULD TAKE MORE THAN MORE PIXELS TO MAKE ME LOOK GOOD

ICEMAN

ITEMS OF INTEREST



CASA-Children Worth Saving, Inc.
2008 1st Ave. Suite 806
PO Box 843
Dodge City, KS 67801-0843
Phone (620) 225-1278
Fax (620) 225-0815

July 31, 2017

Brothers of the Third Wheel
Mr. Alex Ross
PO Box 2550
Cortaro, AZ 85652-2550

Dear Mr. Ross,

On behalf of CASA-Children Worth Saving, Inc. I want to say thank you for your \$1,000.00 award check and selecting us as the local charity to receive a donation. Your thoughtful gift will help ensure that we may continue to serve the abused and neglected children of Clark, Comanche, Ford, Gray, Kiowa, and Meade counties.

I appreciated the opportunity to meet you and the other BTW members. It was exciting to learn about BTW and see the variety of trikers at the Trike Show. Gifts, such as yours, go towards our efforts to provide highly trained and skilled volunteer advocates to children who urgently need a stable and positive adult in their lives.

We are grateful you chose Dodge City as your National Trike-In location and hope to see you in 2018. Partnership and collaboration play a significant part in helping us realize our goal of providing advocates who dedicate their lives to finding a safe and permanent home for every child. Thank you!

Sincerely,

Kristin Hines
Executive Director

Mission Statement: *Investing in abused and neglected children with a volunteer's voice in court by seeking a safe and permanent home for each child.*

United Way Partner Agency

ITEMS OF INTEREST

HAND SIGNALS



Left turn
Arm and hand extending left, palm facing down.



Right turn
Arm out, bent at 90° angle, fist clenched.



Stop
Arm extended straight down, palm facing back.



Speed Up
Arm extended straight out, palm facing up, swing upward.



Slow Down
Arm extended straight out, palm facing down, swing down to your side.



Follow Me
Arm extended straight up from shoulder, palm forward.



You Lead/Come
Arm extended upward 45°, palm forward pointing with index finger, swing in arc from back to front.



Hazard in Roadway
On the left, point with left hand; on the right, point with right foot.



Single File
Arm and index finger extended straight up.



Double File
Arm with index and middle finger extended straight up.



Comfort Stop
Forearm extended, fist clenched with thumb up and down motion.



Refreshment Stop
Fingers closed, thumb to mouth.



Turn Signal On
Open and close hand with fingers and thumb extended.



Pull Off
Arm positioned as for right turn, forearm swing toward shoulder.



Cops Ahead
Tap on top of helmet with open palm down.



Fuel
Arm out to side pointing to tank with index finger extended.

ITEMS OF INTEREST

FROM: Gilles LIETTI Director

Hi Alex, 440 Trikes crews (trikes, Spyders, bike-conversion, Slingshots ...). They came from all over France and the following countries: Germany, Belgium, Netherlands, Luxembourg, Italy, Switzerland, Spain. We also welcomed 16,000 visitors during the Weekend. 386 Trikes baptisms were made for a charity.

BTW-France created the first European showroom of trikes manufacturers. The following manufacturers were present: BOOM, REWACO, HANNIGAN, POLARIS, BRP CANAM, HARLEY DAVIDSON, KASZPIR TRIKE, LAZARETH, SMT TRIKE, YUKON MOTOR TECHNOLOGY

Gilles LIETTI Director

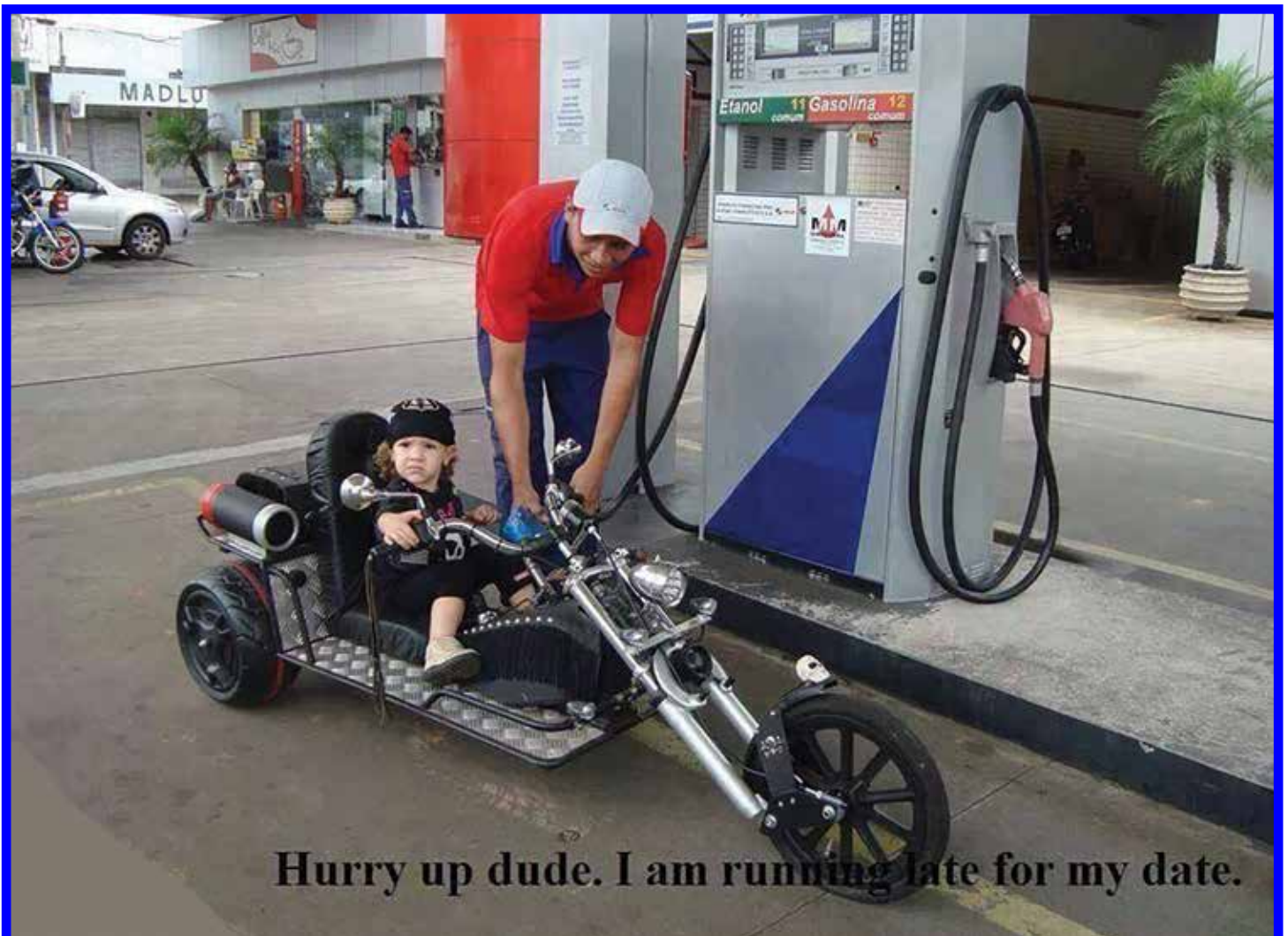

Hurry up dude. I am running late for my date.

TRAILER LIGHTING REQUIREMENTS



When you're out on the road pulling your trailer, you want to be as safe as possible. One important component of towing safety is visibility - making sure other drivers can see your trailer. And lighting plays a big role in visibility. So, whether you're replacing a single light bulb or lens cover, or you're adding a complete set of lights to a homemade trailer, you want to get the right part for the job.

You also want to get lights that comply with the US government's lighting requirements for trailers. Based on standards developed by the Society of Automotive Engineers (SAE), the National Highway and Traffic Safety Administration (NHTSA) has developed requirements for vehicle lights.

The set of regulations that applies to vehicle lighting is known as FMVSS 108, and it includes lighting requirements for trailers. These regulations define how many lights a trailer must have, where the lights should be located, what performance standards the lights must meet, and how manufacturers must label lighting components.

Note: The information contained in this article is based on the US government's regulations pertaining to vehicle trailer lighting. These regulations can be found under Title 49, Part 571, Section 108 of the Code of Federal Regulations. This section covers lamps, reflective devices, and associated equipment related to motor vehicles. To see these regulations and to get the most up-to-date information, visit the [US government's Electronic Code of Federal Regulations](#).

This article will help you answer the following questions:

- [What lights and reflectors must my trailer have?](#)
- [Where do I mount these lights on my trailer?](#)
- [What standards must trailer lights, reflectors, and reflective tape meet?](#)
- [What is the difference between lights with a "C" in their code \(PC and PC2\) and those without \(P2 and P3\)?](#)
- [What is the difference between lights that are for trailers wider than 80" and those that are not?](#)
- [What is the difference between non-submersible, submersible, and waterproof lights?](#)

Determine Which Lights Your Trailer Needs

All trailers are required to have [stop lights](#), [tail lights](#), [turn signals](#), and [reflectors](#). Trailers that are 80" wide or wider, or that are 30' long or longer need additional lights and reflectors. A trailer that is 80" wide or wider and has a Gross Vehicle Weight Rating (GVWR) over 10,000 lbs requires [conspicuity treatments](#). These treatments consist of strips of reflective tape or rows of individual reflectors that create an alternating pattern of red and white along the sides and rear of a trailer to make it easier to see.

To determine which lights a trailer needs, you need to know the trailer's overall length and width and whether the trailer's GVWR is greater than 10,000 lbs. If you don't know the dimensions of your trailer, you'll have to measure it. To find your trailer's GVWR, look for a sticker located somewhere on the trailer.

Measuring the Length of a Trailer

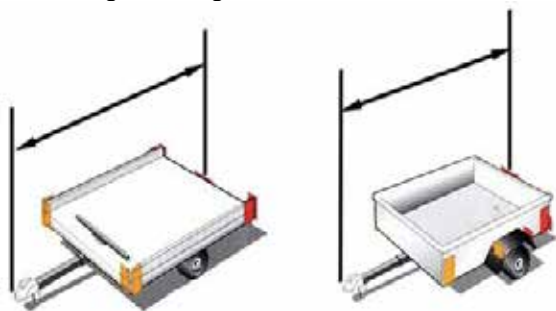

To find a trailer's length, measure from the rearmost point on your trailer to the point of the trailer closest to the vehicle. Be sure to include the coupler or any overhang in this measurement.

Measuring the Width of a Trailer

To find the width, measure at the trailer's widest point. This measurement must include any overhang or protruding fenders.

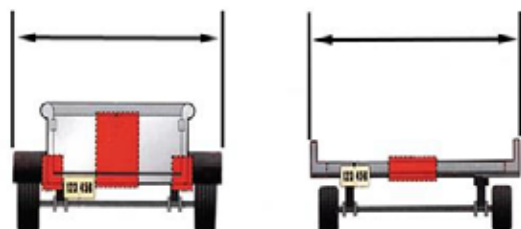

Locate Trailer GVWR

FOR MORE INFO GO TO
www.etrailer.com/faq-trailer-lighting-info-and-regulations.aspx

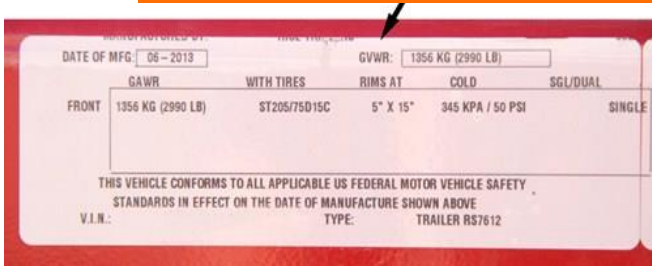

To find a trailer's GVWR look on the trailer's tongue or frame for a plate; you will find the GVWR there.

Once you know your trailer's length, width, and GVWR, you can use the following list to find the specific lights for your trailer.

- Trailer is less than 80" wide and less than 30' long
- Trailer is 80" or wider, less than 30' long, and has a GVWR of 10,000 lbs or less
- Trailer is 80" or wider, 30' or longer, and has a GVWR greater than 10,000 lbs
- Trailer is 30' or longer (regardless of width or GVWR)

Required Lights for Trailers Less Than 80" Wide and Less Than 30' Long

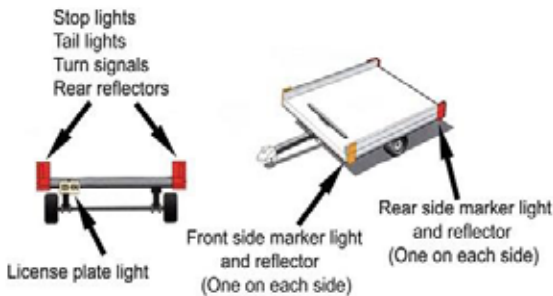

| Required Lights | |
|--------------------------------|---|
| 2 Stop/brake lights | These functions are frequently found together in combination tail lights. |
| 2 Tail lights | |
| 2 Turn signals | |
| 2 Rear reflectors | |
| 1 License plate light | |
| 2 Rear side marker lights | |
| 2 Rear side reflectors | |
| 2 Front side marker lights | These functions are frequently combined into a single side marker light. |
| 2 Front side marker reflectors | |

Exceptions

- If your trailer is less than 6' long, you do not need to have front side marker lights or front side marker reflectors.
- If your trailer is less than 30" wide, you only need to have 1 brake light, 1 tail light, and 1 rear reflector. These lights should be mounted at the center of the trailer, rather than on an outer edge.

Required Lights for Trailers 80" or Wider, Less Than 30' Long, and with a GVWR of 10,000 lbs or Less

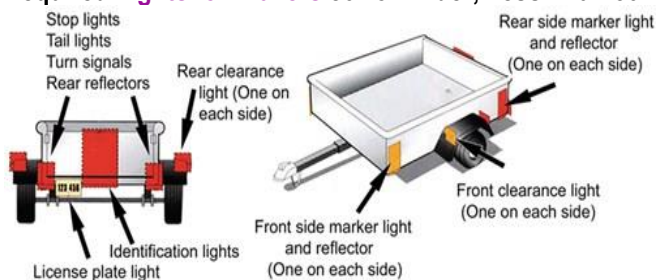

SAVINGS

Vendor Partners

SAVINGS

These Vendors offer discounts and special pricing to all members of Brothers of the Third Wheel, who show their Membership Card at time of purchase.

ARKANSAS

SHADY OAKS CAMPGROUND & RV PARK, Harrison, AR. Owner: Terri Cochrane, fellow BTW Member says the facility is trike and motorcycle friendly and they offer a **15% discount to all BTW members**. Go to www.camptheoaks.com, email them at camptheoaks@cox.net or phone 870-743-2343. "Our location provides miles of great riding here in the Ozark Mountains. Shady Oaks offers beautiful wooded acres and accommodates everything from primitive tent camping to 42 ft toy haulers, and everything in-between, plus 1 full cabin, and 2 camper cabins, pavilion, pool clean bathrooms, laundry, store, and much more. Hope to see ya'll."

CALIFORNIA

TRIKEMASTER: Custom chopper style, VW trikes. Complete trike or kit. Automatic or 4 speed, and repairs. Jim Sexton, 9680 Palm Lane, Fontana, CA 92335. 909-350-3201. **BTW receive a free accessory worth up to \$100 with their purchase.**

JH Enterprises national distributors of **Wenol Metal Polish**

6391 Linda Lee Dr Yucca Valley, CA 92284 (760)365-5639 www.wenol-polish.com

INDIANA

CHEETAH TRIKES: 4-cyl, V6 or V8 automatic. Flawless design, high quality and the best materials have created a comfortable ride and fingertip control that make Cheetah's the smart choice for a trike. The value of buying at factory direct prices is also a good choice. www.cheetahtrikes.com, 812-256-9199. **We offer BTW a discount.**

RENEGADE TRIKES: Several engine choices - 6 cylinders to big block V8's, 3 - 4 speed automatics, cornering capabilities that rival sports cars. 3 models with tops and optional cab enclosures, 4 open models. Also available in kit form. www.renegadetrikes.com, Clarksville, IN, 812-941-9900. **We offer 1/2 off the first \$500.00 of upgrades.**

IOWA

MACS HOTROD SHOP: V8 Trikes, chassis parts, see web site macshotrodshop.com, 402-305-2863, 34625 L ave. Adel Ia. 50003 E-mail: mac@macshotrodshop.com **BTW members receive up to 10% Discount on purchases.**

KANSAS

PREMIER TRIKES, INC.: The Premier "Roadstar" is a luxurious ride. The Roadstar is powered with a 4.3 Chevy V6 engine and a 700R4 automatic transmission. See our 1/2 page ad or visit www.premiertrikes.com. We also custom build trikes. Wayne or Jeff Eck, 316-744-2841. **We offer BTW Members special Discount pricing.**

MISSOURI

CLEAR CREEK COACH: Clear Creek Coach for hire. A memorable tribute as alternative transportation for your loved one from the funeral home, church or chapel to their final resting place. Special rates apply for veterans, fire fighters, law enforcement, BTW members. www.clearcreekcoach.com, 417-432-3511. **Special offer to BTW.**

NEVADA

Doghhouse VW Trike specialists and partx supplier and The New West Coast **Rewaco** Dealer. check us out at doghouserepairs.com. **Offers BTW Member Discounts**

NEW MEXICO

LIGHTNING V-8 MOTORCYCLES: Top of the line custom-built V8 trikes. Rolling chassis or turnkey. Small or big block. 305 Conchas SE, Albuquerque, NM 87123 or 866-999-1958, email trykes505@gmail.com **We offer BTW Members special Discounts.**

NORTH CAROLINA

CUSTOM BUILT MOTORS LLC. Custom hand built fiberglass body vw trikes, frames, fiberglass bodies and fenders, wide leading link front ends, rolling chassis. Standard 4 speed or All hand control auto stick or full auto available. Several different body styles and frames. Also a complete automotive engine machine shop with vw machining service available. Brad Stephens, Asheboro, NC 336-302-8838 noon-8 pm please. custombuiltmotors@outlook.com **WE OFFER up to 10% off to BTW MEMBERS.**

PLEASE LET THESE VENDORS KNOW YOU FOUND THEM IN THE "TRIKER"

BTW EVENTS CALENDAR

Sept 15-17, 2017

13th Annual High Country Area Blowout

Payson Campground & RV Resort, 808 E Hwy 260. For camping reservations, call 928-472-2267.

Majestic Mountain Inn, 602 E Hwy 260. For reservations, call 928-474-0185 or 800-408-2442. Mention BTW and receive a discount. All day Friday-suggested rides in the beautiful pines and Meet & Greet. Saturday-Fun ride, group events, awards & dinner. For info: Bill (Rackem) Magby, 928-442-6310 or cvbrm01@gmail.com.

Sept 15-17, 2017

KANSAS State Trike-In 2017 at Community Building, Garnett KS.

Memorial Ride, Cookout Nursing Home Ride, Run to Sonic and Dairy Queen, trike Show, Event run, Sat Dinner, Silent Auction, Sun Breakfast, & worship, Reg \$20 Lodging Economy Inn 7854486816, Garnett Inn 785 448-6800 for more info contact Ray Scales 620-238-1844

Oct. 12 -14, 2017

Arkansas State Trike Rally, Wonderlust Camp Ground, Eureka Springs, AR. for camping call Wonderlust Campground, 1-479-253-7385, www.wonderlust.com daily 50/50s Door prizes, rides, Fri. nite hotdog roast, Sat Nite door prize drawing & AR. State Meeting. event patch \$5, to be sold at rally. for more info contact Jimmy Anderson 501-388-1680 or 501-556-5872 jajustlazy@gmail.com

Oct 19-22, 2017

California State Fall Trike-In

at Madera Fairgrounds, a850 W. Cleveland Ave Madera CA. 93637 Trike-In \$10 per person 13 & under Free Camping \$15 per nite, for more info contact Loner at 559-781-8129 email lonerbtw@att.net

Oct 28th, 2017

2nd Annual Monster Taco & Chili Bash

hosted by Central AZ Sidewinders, 29362 N. Varnum Rd. San Tan Valley, AZ 85143. tacos, chili, soda Water, Beans Rice, Desserts, \$15 per couple, \$8 per person, Auction, 50/50 prizes, please RSVP by Oct 1, for more info contact Flo Southward text 480-250-6952 or lfsouthworth@Q.com

Nov 10-12, 2017

17th ANNUAL TURKEY FEST

Southern AZ Smokin Eagles & Desert Renegades, Quail Ridge RV Park, Huachuca City, AZ, 2207 N. Yucca Dr. Huachca City, AZ 85616 Auction turkey dinner, Turkey provided by the chapters, for more info contact lou Kaden 520-249-7410 or Jack Mertes 520-490-2463

Mar 15-17, 2018

2018 Western Regional Trike-In Riverside Resort & RV Park, Laughlin NV Activities planned for the week of Mar 11-17, 2018. St Patricks Day Pot Luck, Auction & Meeting following dinner new rides & activities planned. jackregion9btw@dakotacom.net

In Memory of Trikers Lost



For Your Final Journey...
Why should the end of your life be any different than the way you lived it? Respectfully providing a memorable alternative for your loved one's final ride. Contact the company nearest you for more information.



Krause Funeral Home (Milwaukee, WI) 414-464-4640
Michigan Memorial (Detroit, MI) 734-783-2646
Sujkowski F.H. Northpointe (Toledo, OH) 419-476-9176
Unique Limousine (Harrisburg, PA) 717-233-4431

**IF WE RECEIVE ANY INFORMATION FOR THE MAGAZINE
A CONFIRMATION EMAIL IS SENT NOTIFYING THE SENDER THAT WE
RECEIVED SUCH AND IT SHOULD THEN BE FOUND IN THE NEXT ISSUE OF
THE MAGAZINE**

**IF YOU DO NOT SEE YOUR NEWS IN THIS SECTION, PLEASE CONTACT
HEADQUARTERS TO RESOLVE ANY PROBLEMS**

In Memory of Trikers Lost



We have lost a dear friend, and pillar of the Coastal Cruisers Chapter of the BTW. James F. Churchward known by all as "Churchy", passed away unexpectedly in his home on June 28th, 2017 at age 73. Churchy, native of Tacoma, attended Wilson High School and graduated Class of 1961 where he went on to serve three years in the United States Navy (1961-1964). He had a 16-year career at C&G Electronics Co. and continued his education at Tacoma Community College which later led him to starting up his own business. Starting in 1977 Churchy began his most infamous project, The Trike. Shown at various car and motorcycle shows through 1979 where it received praise and several top awards. In 2006, after 27 years in storage, he began the restoration of his trike, which included transforming the trike into a two-seater so Linda could accompany him. Churchy's passion led him to becoming a member of Brothers of the Third Wheel in 2007 and State Director of BTW in 2015. He also served several years as Road Captain for the Coastal Cruisers. He was the major influence in the forming of three new BTW chapters in Washington state.

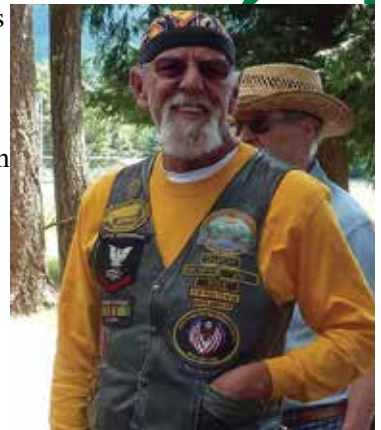

He also served as a professional Santa for 15 years before he retired, starting with the American Heart Association of Washington and ending with The Juvenile Diabetes Research Foundation. He put smiles on the faces of many children. Churchy is survived by his wife, "he would say the best thing that ever happened to him", Linda Churchward, 3 children: Lisa (Loy), John (Corie), and Jason (Lorraine), 11 grandchildren, and 9 great grandchildren. He is also survived by two brothers, CW Churchward of Gulf Breeze, FL, Budd Churchward of Birch Bay, WA, and one sister, Maggie Law of San Juan Island, WA. Churchy will be forever loved by his extensive extended family, friends, and neighbors. Churchy was known for his kindness, love for family, jack of all trade skills, and willingness to lend a helping hand.

Words do no justice to the "pebble in the pond" legacy he has left for us all.

On July 22 while on a toy run ride with fellow BTW riders of the BC chapter, dear brother Kris Klassen, flying our flag, was suddenly called to the great ride in the sky. He heroically steered his mighty V-8 powered trike out of danger to all others as his last act in our world. Prior to that, he was chauffeuring Santa on the morning section of the toy run. At lunch, he remarked that "this is the best ride ever". Amongst the trophies that day was that for "Longest Distance Travelled". Ironically, he rode all the way to the Pearly Gates. When Kris departed this world, he was literally doing what he loved; surrounded with family members; surrounded with friends. Not many of us go out in such style. Kris was always keen to share his knowledge and love of trikes. For those who met him, he was instantly one's Best Friend Forever. That's no exaggeration. Yes, Kris will be missed by us all. Deeply and Sincerely. It comforts us to know that he is now riding with the angels and preparing a place for us all. Our heartfelt condolences and blessings go to Kris's family and dear friends. Ride On, Brother Kris



May They Rest In Peace.



GUIDELINES for CHAPTER DIRECTORS

DIRECTOR GUIDELINES **CHAPTER DIRECTORS**

DUTIES:

- * Responsible for making all information from BTW available to all members of the chapter.
- * Providing pertinent information of each and every member of the chapter to BTW
- * Have availability of email service to correspond with BTW and the chapter members
- * Coordinate a minimum of 3 rides per year, that are to be posted in an appropriate time frame and location for members and non members to be able to participate in these rides.
- * Hold at least an annual meeting.
- * Make available information about local events that chapter members might be interested in attending as BTW members.
- * Verify that all chapter members are current with their membership.
- * Arrange for the additional positions needed to operate chapter.

TERM: 1-3 year term, max 3 terms unless overridden by a majority member vote.

STATE DIRECTORS

DUTIES

- * Responsible for making all information from BTW available to all of the chapters in the State.
- * Confirming pertinent information of each and every member of all the chapter in the state to BTW.
- * Have availability of email service to correspond with BTW and the Chapters in the state
- * Coordinate a State event, that is to be posted in an appropriate time frame and location for members and non members to be able to participate in these rides and submitted to BTW for Event posting.
- * Attend as many chapters activities as possible and evaluate member needs.
- * Make available information about events taking place in the State that chapter members might be interested in attending as BTW members.
- * Verify that all chapter are current with their membership and are properly represented.

TERM: 3year term, max of 3 terms unless overridden by a majority vote of the members

REGIONAL DIRECTORS

DUTIES

- * Responsible for making all information from BTW available to all of the members in the region.
- * Confirming pertinent information of each and every member in the region to BTW.
- * Have availability of email service to correspond with BTW and the members in the Region.
- * Coordinate a Regional event, that is posted in an appropriate time frame and location for members and non members to be able to participate in these rides and submitted to BTW Event posting.
- * Attend as many chapters activities as possible and evaluate member needs.
- * Make available information about events taking place in the Region that members might be interested in attending as BTW members.
- * Verify that all chapter are current with their membership and are properly represented.

TERM: 3year term, max of 3 terms unless overridden by a majority vote of the members

***THIS ASSOCIATION IS OWNED AND OPERATED BY & FOR ALL THE MEMBERS
STEP UP AND BE A PART OF IT***

Directory

INTERNATIONAL HEADQUARTERS

Assistant Executive Officer:
Jim Lee

Chief Executive Director
Alex Ross

Executive Officer
Kathryn Henry

Office Manager
Lynne Ross

E-mail: trikers@btw-hq.net

Web: <http://btw-trikers.org>

Intl. Director of Online Public Relations: **Steve Mundell**

Magazine Editor: **Alex Ross**

BOARD OF DIRECTORS

| <u>Member</u> | <u>Contact Information</u> | | <u>Position</u> |
|-------------------------|-----------------------------------|--|-------------------------------------|
| Alex Ross | 520-334-0534 | alex@btw-hq.net | Executive Director |
| Jim Lee | 815-342-8181 | illinoisbtw@yahoo.com | Assistant Executive Director |
| David John Longstaff | 079-663-99748 | davel@qitc.com | International Director |
| Wayne Eck | 316-744-2841 | wayne@kceind.com | Interim Regional Director |
| Cathy "Cat" Schoubroeck | 870-715-9507 | cbroecks@hotmail.com | Interim Regional Director |
| Jack Mertes | 520-490-2463 | jackregion9btw@dakotacom.net | Regional Director |
| Kathryn Henry | 360-923-0133 | kathryn.henry66@yahoo.com | Assistant Executive Director |

ANY BTW MEMBER, DEALER OR MANUFACTURER CAN OFFER A 1ST YEAR BTW MEMBERSHIP TO A BUYER OF THEIR TRIKE, IF THE BUYER IS A NON-MEMBER.

ANY NON MEMBER PURCHASING A TRIKE FROM A MEMBER, MANUFACTURER OR DEALER CAN OBTAIN A 1st YEAR FREE MEMBERSHIP THROUGH THAT DEALER, MANUFACTURER OR MEMBER, BY HAVING THEM CONTACT BTW HEADQUARTERS.

THIS FIRST YEAR MEMBERSHIP INCLUDES OUR TRIKER MAGAZINE IN DIGITAL FORMAT.

continued...

Contact Information for Regional Directors

CONTACT INFORMATION BY REGION

| <u>REGION</u> | <u>TERRITORY</u> | <u>CONTACT</u> | |
|---------------|-------------------------------------|-------------------------|---------------|
| #1 | AK, HI, ID, OR, WA, BC | Kathryn Henry | 360-923-0133 |
| #2 | KS, MO, NE, OK, TX | Wayne Eck | 316-744-2841 |
| #3 | MT, ND, SD, WY, AB, SK, NWT | Kathryn Henry | 360-923-0133 |
| #4 | IA, IL, IN, MI, MN, OH, WI, MB, ONT | Jim Lee | 815-342-8181 |
| #5 | AR, KY, LA, MS, TN | Cathy "Cat" Schoubroeck | 870-715-9507 |
| #6 | AL, FL, GA, NC, SC | OPEN | (Contact HQ) |
| #7 | DE, MD, NJ, PA, VA, WV | OPEN | (Contact HQ) |
| #8 | NY, VT, CT, MA, RI, ME, NH, NL, QC | OPEN | (Contact HQ) |
| #9 | AZ, CA, CO, NV, NM, UT | Jack Mertes | 520-490-2463 |
| #10 | UK chapters | David John Longstaff | 079-663-99748 |

REGIONS 6,7 & 8 ARE CURRENTLY OPEN, ANYONE INTERESTED IN TAKING ONE OF THESE POSITIONS, PLEASE CONTACT THE OFFICE AT 520-789-7265
WE HAVE MANY MEMBERS JOINING OUR ASSOCIATION IN OTHER COUNTRIES AND WE ARE LOOKING FOR AREA REPRESENTATIVES FROM THOSE COUNTRIES AS WELL.

State and Chapter Director Contact Information

| <u>CHAPTER</u> | <u>DIRECTOR</u> | <u>LOCATION</u> | <u>CONTACT #</u> | <u>FACEBOOK</u> | <u>E-MAIL</u> |
|---|-----------------------------|-----------------|------------------|-----------------|----------------------------|
| USA | | | | | |
| Alabama: | | | | | |
| State Director: LOOKING FOR DIRECTOR | | | | | |
| South Alabama Trikers | David Belcher | Axis | 251-802-8824 | | Johndavidbelcher@gmail.com |
| Alaska: | | | | | |
| Looking for a Director | | | | | |
| Arizona: | | | | | |
| State Director: LOOKING FOR DIRECTOR | | | | | |
| Central AZ Sidewinders | Florine "Flo" Southworth | Central AZ | 480-250-6952 | | lfsouthworth@q.com |
| Desert Renegades | Jim Alley | Tucson | 520-398-4465 | | jalley7@cox.net |
| Free Spirit Trikers | Looking for Director | | Kingman Area | | |
| High Country Area | Bill Magby | Prescott | 928-442-6310 | | cvbrm01@gmail.com |
| Southern AZ Smokin Eagles | Louella Kaden | Benson | 520-249-7410 | | glkaden@powerc.net |
| Superstition Area | Ben Vega | Chandler | 480-785-2683 | | Phoenixbtw.com |

State and Chapter Director Contact Information

continued...

| CHAPTER | DIRECTOR | LOCATION | CONTACT # | FACEBOOK | E-MAIL |
|---------------------------------------|-------------------------------|-------------------------|---------------------|--|-------------------------------|
| Arkansas: | | | | | |
| State Director: | Jimmy Anderson | Romance | 501-388-1680 | | jajustlazy@gmail.com |
| Freedom Riders | Cathy "Cat" Schoubroeck, | Harrison | 870-715-9507 | BTW-"Freedom Riders" of Northwest Arkansas | cbroecks@hotmail.com |
| Misfits | Looking for Director | | | | |
| Russellville Area Trikers | James Lucius | Russellville | 479-979-5441 | | lucius1946@yahoo.com |
| Twin Lakes Trikers | Looking for Director | | | Contact Jimmy Anderson 501-388-1680 | jajustlazy@gmail.com |
| California: | | | | | |
| State Director: | Loner Abbott | Porterville | 559-781-8129 | | lonerbtw@att.net |
| Antelope Valley | Dean Yates | Juniper Hills | 661-944-0296 | | yatesdean@yahoo.com |
| Bakersfield Jammin 3 Wheelers | Jim Long | Bakersfield | 661-809-6657 | | longbak4@aol.com |
| Central Valley | Margaret Winebrenner | Fresno | 559-916-9037 | | margaretsue@prodigy.net |
| Modesto Chapter | Linda Jordan | Modesto | 209-544-8339 | | kittymom04@aol.com |
| Long Beach Cruisers | Andrea Kimes | Long Beach | 310-993-6329 | | longbeachcruisers15@gmail.com |
| NorthEast WindRider Trikers | Bill Duncan | Oroville | 530-532-1490 | www.facebook.com/groups/btwnewindriders | trikerbill14@gmail.com |
| Redwood Empire Trikers | Kaleb Gaddis | Winton | 209-489-0639 | | kalebgaddis@att.net |
| River City Trikers | Reggie Joaquin | Roseville | 916-505-9907 | | Reginald.joaquin@yahoo.com |
| SanDiego Area | Sharon"Scottie" Sisemore | Chula Vista | 619-426-1884 | | btwscottie@cox.net |
| San Gabriel Valley | Robert Gallegos | West Covina | 626-926-3018 | | RobertGallegos@verizon.net |
| Sonora Area | Jerry Palmer | Sonora | 209-532-3235 | | blueiron86@comcast.net |
| Tulare County Freedom Riders | Robert (Cowboy) Coy, | Tulare | 559-361-4343 | | bcoy@earthlink.net |
| San Francisco Bay Area Trikers | David Theroff | | 408-705-3768 | | masterdovidt@me.com |
| Colorado: | | | | | |
| State Director: | Bill Haskett | Colorado Springs | 719-598-5531 | | bhaske@aol.com |
| Mile High Trikers | Gigi Johnson | Denver area | 720-980-6655 | | bluwave36@yahoo.com |
| Pikes Peak Chapter | Bill Haskett | Colorado Springs | 719-598-5531 | | bhaske@aol.com |
| Connecticut: | | | | | |
| | | | | | Looking for Director |
| Delaware: | | | | | |
| | | | | | Looking for Director |
| Florida: | | | | | |
| State Director: | J B Baldwin | Ocala | 352-216-9704 | | x13ornng@netscape.net |
| Brothers Ocala | JB/Carol Ann Baldwin | Ocala | 352-216-9704 | | x13ornng@netscape.net |
| Chain of Lakes Trikers | Eddy Varela | Lakeland | 863-660-7731 | | Baddog025@gmail.com |
| First Coast Trikers | Rob Bourne | Fernandina Beach | 904-535-3104 | | rbourne3@thebournes.us |
| Gold Coast Chapter/South Fl | George Torrence | Weston | 954-385-2837 | | gtorr@bellsouth.net |
| Lake County Trikers | Melvin "Tiny" Adkins | Eustis | 352-250-9601 | | |
| North Ft. Meyers Chapter | Looking for Director | | | | |
| Nature Coast Trikers | Joe Graves | Williston | 352-208-0517 | | capjoe2@att.net |
| Palm Coast Area | Looking for a Director | | | | |
| Georgia: | | | | | |
| State Director: | Cam McCallister | Danielsville | 706-540-4950 | | aircooled08@yahoo.com |
| NorthEast Georgia Trikers | Cam McCallister | Danielsville | 706-540-4950 | | aircooled08@yahoo.com |
| Southeast Georgia Twisted Spokes | Looking for Director | | | | |
| Idaho: | | | | | |
| State Director: | Kay Cluff | Gooding | 208-220-1468 | | kaycluff696@gmail.com |
| SE Wind Riders | Looking for Director | | | | |
| Treasure Valley Trikers | Jim Lee | Emmet | 208-365-2825 | | bettyrainey@msn.com |

State and Chapter Director Contact Information

continued...

| CHAPTER | DIRECTOR | LOCATION | CONTACT # | FACEBOOK | E-MAIL |
|-------------------------------|-----------------------------|----------------------|-----------------------------|------------------------|------------------------------------|
| Illinois: | | | | | |
| State Director: | Jim Lee | Joliet | 815-439-2672 | | illinoisbtw@yahoo.com |
| Central Illinois Trikers | Looking for Director | | | | |
| Cross Creek Trikers | Dave Mendalsk | Joliet | 630-810-9330 | | dmasdfjkl@gmail.com |
| Eagle Rock Riders | Kevin Melberg | Rock Falls | 815-625-4150 | | kevinnbarb@yahoo.com |
| Indiana: | | | | | |
| State Director: | Randy Griffin | Michigan City | 219-210-1048 | | goosetriker@gmail.com |
| Circle City Trikers | Looking for Director | | | | |
| City of Firsts Trikers | Jim Langsdorf | Delphi | 765-481-8859 | | langsdorfjim@yahoo.com |
| NW Too Much Fun Bunch | Ed Cooney | Michigan City | 219-210-1304 | | ecooney@gmail.com |
| Tribal Trikers | Dick Enochs | Hartford City | 765-348-4473 | | |
| Iowa: | | | | | |
| State Director: | Dave Hopman | Newton | 641-792-8127 | btw-trikersiowa | leeh@iowatelecom.net |
| Great River Riders | | | Looking for Director | | |
| Iowa Heartland Trikers | Dave Hopman | Newton | 641-792-8127 | | leeh@iowatelecom.net |
| Siouxland Trikers | Fred Reese | Bronson | 712 9483649 | | freese@wiatel.net |
| NW Lake Tripods | Robert Kepler | Ruthven | 612-209-2330 | | willys39sd@hotmail.com |
| Kansas: | | | | | |
| State Director: | Ray Scales | McCune | 620-632-4606 | | raymondscales0849@gmail.com |
| East Central Kansas | John Privett | Ottawa | 785-248-3867 | | j-jprivett@sbcglobal.net |
| KAW Valley Trikers | Tom Wing | Kansas City | 913-236-7790 | | gtrdntrike@yahoo.com |
| Open Prairie Trikers | Larry Lee | Derby | 316-201-6289 | | larrychshog@gmail.com |
| Southeast Kansas | Ray Scales | McCune | 620-632-4606 | | raymondscales0849@gmail.com |
| Tornado Alley Trikers | John Starks | Hutchison | 620-665-1176 | | jbarstar1@hotmail.com |
| Kentucky: | | | | | |
| State Director: | Gene Renfro | Calvert City | 270-703-7476 | | renwall1@yahoo.com |
| Kentuckiana Slo-Pokes | Looking for Director | | | | |
| Kentucky Trikes Unlimited | | | | | |
| Twin Lakes Trikers | Ricky Carby | Leitchfield | 270-287-1348 | | rcarby59@yahoo.com |
| Western Kentucky Trikers | Gene Renfro | Calvert City | 270-703-7476 | | renwall1@yahoo.com |
| Louisiana: | | | | | |
| State Director: | | | Looking for Director | | |
| Ark-La-Tex Trikers | | | Looking for Director | | |
| Maine: | | | | | |
| State Director: | Doc Lessard | Lewiston | 207-777-3346 | | doc2fab@aol.com |
| Maryland: | | | | | |
| Interim State Director | Tim Schaeffer | Manchester | 443-375-2041 | | timlschaeffer@gmail.com |
| Massachusetts: | | | | | |
| State Director: | Al Womack | Lynn | 781-598-5316 | | womackalponse@hotmail.com |
| Michigan: | | | | | |
| State Director: | Judy Bowker | Highland | 248-889-2276 | | nailstazpc@comcast.net |
| Minnesota: | | | | | |
| State Director: | Dan Krulish | Lonsdale | 612-756-4412 | | dan@dzldoc.com |
| Prairie Wind Riders | Dave Stone | Chippewa Falls, WI | 715-723-5050 | | |
| Mississippi: | | | | | |
| State Director: | | | Looking for Director | | |

continued...

State and Chapter Director Contact Information

| CHAPTER | DIRECTOR | LOCATION | CONTACT # | FACEBOOK | E-MAIL |
|----------------------------------|-----------------------------------|--------------------|---------------------|----------------------------------|----------------------------------|
| Missouri: | | | | | |
| State Director (Interim) | Jerry Ducker | Ozark | 417-761-9864 | | ozarkmntnpaw@cebridge.net |
| Central MO Trikers | Carl Lee | Rolla | 314-833-0508 | | wainlee@hotmail.com |
| Gateway Chapter | Howard "Crash" Telthors | Sullivan | 314-520-2063 | | btwtrike@fidmail.com |
| Heart of America Trikers | David Rapsom | Columbia | 816-261-9153 | | rapson_d@yahoo.com |
| 1-70 Chapter | Mike Burgess | High Hill | 636-359-3522 | | gascap123@live.com |
| Ozark Mtn. Trikers | Al Bilyeu | Walnut Shade | 417-561-4941 | | abilyeu2@gmail.com |
| Ozark Road Hogs | Nick Catrow | Thayer | 417-264-2307 | | n0dad@arrl.net |
| Route 66 Trikers | Al Leslie | Wheatland | 417-818-2393 | | HCSD2331@yahoo.com |
| Tri-Roller Trikers | Morris Jarrett | Neosho | 417-451-7957 | | morrisjarrett27@yahoo.com |
| St. Joseph MO (Contact) | "Cowboy" Countryman | St. Joseph | 816-259-2236 | | rustynailhbc@gmail.com |
| Montana: | | | | | |
| State Contact: | LOOKING FOR A DIRECTOR | | | | |
| Nebraska: | | | | | |
| State Director: | Melvin "Butch" Maas Wilber | | 402-821-2287 | | cobumaas@yahoo.com |
| Grand Island Area | Ron Thompson | St. Paul | 308-754-8592 | | rthompsonvt@hotmail.com |
| Nevada: | | | | | |
| State Director: | Jody Pankow | Las Vegas | 702-336-8283 | | jodypankow@yahoo.com |
| Pahrump Trikers | Tim Mattoon | Pahrump | 907-229-3227 | | tlmmattoon@hotmail.com |
| Southern NV Road Runners | Bob Trigg | Las Vegas | 775-297-2822 | | kc7utk@yahoo.com |
| Pahrump Free Riders | Paul Farley | Pahrump | 651-999-9140 | | EBC84TH@AOL.COM |
| Nevada Syder Ryders | Tom Kaplan | Henderson | 702-505-0467 | | tomkaplan1@gmail.com |
| New Hampshire: | | | | | |
| State (Interim) Director: | Robert Kent | Dover | 603-617-0895 | | robert.kent56@yahoo.com |
| New Jersey: | | | | | |
| State (Interim) Director: | Carl "Rib Man" Weinschenk | Monroeville | 856-694-4682 | | |
| New Mexico: | | | | | |
| State Director: | Rock Glaser | Veguita | 505-359-8200 | | rockarue@yahoo.com |
| Albuquerque Altitude | Looking for a Director | | | | |
| La Luz Chapter | Looking for Director | | | | |
| New York: NEW | | | | | |
| State Director: | Robert Gutknecht | Jamestown | 716-665-3372 | | mercimilan09@yahoo.com |
| FingerLakes Area | Kevin Judson | Geneva | 315-789-0491 | | bigk@rochester.rr.com |
| Long Island & Downstate | Looking for Director | | | | |
| North Carolina: | | | | | |
| State Director: | Looking for Director | | | | |
| North Dakota: | | | | | |
| State Director: | Looking for Director | | | | |
| Ohio: | | | | | |
| State Director: | Marc Tyler | Columbus | 614-444-8612 | | tylermarc33@yahoo.com |
| Central Ohio Trike Riders | Russ Russell | Merengo | 419-210-0427 | | casper8180@live.com |
| Cleveland Chapter | Lee Anderson, Jr. | Cleveland | 216-229-7910 | | |
| Mutton Hollow | Mike Hadzima | (Contact) | 740-635-7100 | | |
| North Central Chapter | Kevin Palm | Norwalk | 419-744-2227 | | kapalm1835@yahoo.com |
| North East Ohio (NEO) | | | | | |
| Northwest Ohio (NWO) | Daniel Whitehead | Toledo | 419-290-3493 | | danielt611@gmail.com. |
| Southwest Ohio River Riders | Looking for a Director | | | | |
| Threedom Riders of OH | Bruce Kline | Wadsworth | 330-336-5191 | | threedomriders@aol.com |
| Winged Riders/S. Central OH | Looking for Director | | | | |
| East Central Ohio Riders | Derek Morrison | Lodi | 330-208-3101 | /groups/144080312608145/?fref=nf | mrdmorr@gmail.com |

| CHAPTER | DIRECTOR | LOCATION | CONTACT # | FACEBOOK | E-MAIL |
|---------------------------|-----------------------------|-------------------------------|---------------------|-----------------|--|
| Oklahoma: | | | | | |
| State Director: | Mark Duensing | Tulsa | 918-619-9996 | | oxmotorsports@cox.net |
| NE OK Trikers | Charles Clawson | Spavinaw | 918-530-1189 | | chuckclawson1942@gmail.com |
| Okie Twisters | John McLeod | Oklahoma City | 405-424-2203 | | fojosky@yahoo.com |
| T Town Travelers | Mark Duensing | Tulsa | 918-619-9996 | | oxmotorsports@cox.net |
| Oregon: | | | | | |
| State Director | Looking for Director | | | | |
| Bridge City Trikers | Dave Hancock, | Yacolt, WA | 360-608-3556, | | stfree@centurytel.net |
| Capital City Trikers | Looking for Director | | | | |
| Willamette Valley Chapter | Glenda Christman | Albany | 541-974-6635 | | plindgren1@comcast.net |
| Central Oregon (Contact) | Bear | Redmond | 541-923-2247 | | bear2247@bendbroadband.com |
| Pennsylvania: | | | | | |
| State Director: | | Looking for Director | | | |
| Borderline Trikers of PA | David Snyder | Sharon, PA | 724-866-3281 | | david.snyder3@verizon.net |
| Western Chapter | | Looking for Director | | | |
| Country Road Riders | | | | | |
| Rhode Island: | | | | | |
| Contact: | Richard Young | Providence | 401-516-3469 | | |
| South Carolina: | | | | | |
| State Director: | | Looking for Director | | | |
| Coastal Grand Strand | Brent "Maverick" Davidson | Myrtle Beach | 843-650-2801 | | bdavidson9@sc.rr.com |
| PeeDee | Michael McIntire | Florence | 843-662-9654 | | mcintirr@bellsouth.net |
| Tri-County Triads | | Looking for Director | | | |
| South Dakota: | | | | | |
| State Director: | Bob Grape | Watertown | 605-520-1693 | | mandbgrape@midco.net |
| Tennessee: | | | | | |
| State Director: | Curtis Crawford | Smyrna | 865-258-8173 | | tennesseetravelintrikes@gmail.com |
| Mid TN Wind Riders | Mark "Lefty" Rowison | Tennessee Ridge | 931-721-2260 | | rowison@peoplestel.net |
| Tennessee Travelin Trikes | Curtis Crawford | Smyrna | 865-258-8173 | | tennesseetravelintrikes@gmail.com |
| Texas: | | | | | |
| State Director: | | Looking for a Director | | | |
| San Antonio Area | | Looking for Director | | | |
| Southwest TX Trikers | Dale Bennett | Seguin | 830-734-5621. | | dale.bennett@us.af.mil |
| Utah: | | | | | |
| State Director: | Ray Dorris | Sandy | 801-718-1374 | | raydorris@comcast.net |
| Vermont: | | | | | |
| | | Looking for Director | | | |
| Virginia: | | | | | |
| State Director: | Looking for Director | | | | |
| Coastal Chapter | Jerry Nuckles | Zuni | 757-618-4275 | | nucklesfg2@hotmail.com |
| Shenandoah Valley | | | | | |
| Washington: | | | | | |
| State Director | | | | | |
| Coastal Cruisers | Linda Lu Churchward | Tacoma | 253-759-8474 | | GramFlash@nventure.com |
| Deer Dodger | Jackie Calef | Colville | 509-684-2602 | | jcorr5422@aol.com |
| N Sound Threedom Riders | Russ Lamb | Coupeville | 360-678-1551 | | russlamb57@gmail.com |
| Sage Brush Trikers | Gloria French | Moxee | 509-823-7789 | | beetleart@aim.com |

State and Chapter Director Contact Information

continued...

| <u>CHAPTER</u> | <u>DIRECTOR</u> | <u>LOCATION</u> | <u>CONTACT #</u> | <u>FACEBOOK</u> | <u>E-MAIL</u> |
|--------------------------------|-----------------------------|--------------------|---------------------|-----------------|-------------------------------------|
| West Virginia: | | | | | |
| Looking for Director | | | | | |
| Wisconsin: | | | | | |
| State Director: | Jim Cameron | Norwalk | 608-823-7863 | | kc9pxz@gmail.com |
| NE WI Trikers | William Recla | | 906-774-3821 | | brecla@chartermi.net |
| West Central Chapter | Jim Cameron | Norwalk | 608-823-7863 | | kc9pxz@gmail.com |
| Wyoming | | | | | |
| State Director | Owen Johnston | Wamsutter | 307-370-0931 | | johnstonowen@ymailcom |
| High Plains Trikers | Owen Johnston | Wamsutter | 307-370-0931 | | johnstonowen@gmail.com |
| Powder River Trikers | Denny Steckelberg | Gillette | 307-257-6866 | | denwayne4547@gmail.com |
| Red Desert Ryders SW WY | Brenda Wofe | Wamsutter | 307-460-4228 | | davewolfejr@yahoo.com |
| Canada | | | | | |
| Alberta | | | | | |
| Provincial Contact | Scott Murray | CARDSTON | 403-653-4762 | | btw_alta@telusplanet.net |
| British Columbia | | | | | |
| Provincial Director | Daye Delan | Grand Forks | 604-379-9902 | | Dayeglo777@gmail.com |
| Vancouver Island Chapter | Robert O'Blenis | Courtenay | 250-338-2313 | | rbob@telus.net |
| Manitoba | | | | | |
| Provincial Director | Bernie Kozmeniuk | Roblin | 204-937-2836 | | kozob@live.ca |
| Ontario | | | | | |
| Provincial Director | Kevin Berry | Hanover | 519-364-7910 | | huckdev@sympaico.ca |
| Prince Edward Island | | | | | |
| Looking for Director | | | | | |
| Quebec | | | | | |
| Looking for Director | | | | | |
| Australia: | | | | | |
| Area Director (Interim) | Looking for Director | | | | |
| France | | | | | |
| Area Director | Jean Marc Platret | Gernoble | 068 557-3674 | | jeanmarc.platret@laposte.net |
| Chapter France | Gilles Lietti | Voglans | | | gilles.lietti@orange |
| Holland | | | | | |
| Area Director | Looking for Director | | | | |
| Ireland: | | | | | |
| Chapter Director (Interim) | Looking for Director | | | | |
| New Zealand: | | | | | |
| Area Director | Steven Timmins | Auckland | 09 836 0678 | | trikerdee@yahoo.co.nz |
| Sweden | | | | | |
| Chapter Director | Robert Beckman | Trelleborg | 46709993644 | | beckmans_racing@hotmail.com |
| UK: | | | | | |
| Regional Director | David John Longstaff | | 07966399748 | | davel@qitc.com |
| Area Director | Dean"Punky"Barnitt | Saltash, Cornwall | 0044-175-284-947 | | btw-uk@hotmail.co.uk |
| Scotland Chapter Director | Les Van Acker | | | | |

BTW BOD Elections

BTW is split into 10 Regions; 9 of these regions are in the USA and Canada and the final one covers all areas outside of the USA & Canada. Each Region has a Regional Director. The Regional Directors serve as the Board of Directors. The Board makes decisions regarding the running of BTW, with each Regional Director being elected for a three-year term by the Directors in their Regions. If your Regional Director is not participating in the Board Meetings or being in touch with the Directors in their region, it is up to the membership to request them to step down. The Regions are set out on the Contact page on the forum and in every Triker. For more info, contact Headquarters.

If it is your Region's turn to vote for your Director, have your Chapter or State Director contact HQ and get the documentation for the election.

The nomination period for these posts ends May 1st, and any names submitted will be added to the list of nominees for the regions, if no names are submitted for the position, the previous representatives will remain in their post for the next three years.

As you will see REGION 7 is still awaiting a representative so if you are a fully paid up member in Region 7 (DE, MD, NJ, PA, VA, WV) Please get in touch with HQ and discuss the post and the possibility of you taking this on.

**Brothers of the Third Wheel
An International Family of Trikers**



LOOKING TO BUY A NEW TRIKE?

**Would you like Some or
All of the following Features:**

- *Comfort *Multiple Seating *Cargo Space *Ease of Handling**
 - *Maximum Towing Capacity *Maximum Power when you need it**
 - *Looks and Most of All *Safety**
- Renegade Trikes has been providing our Customers
with all of these features for 33 years.**



This is our New XTL model

Renegade Trikes

www.renegadetrikes.com

**We have many Models to choose from, Open or Enclosed
Multiple Engine & Transmission choices and**

Our Prices are Much Less than many of the new products out there.

Call 1-812-941-9900 for a FREE Brochure

Also Available in Kit Form

***1309 Providence Way
Clarksville, IN. 47129***

BTW
PO Box 2550
Cortaro, AZ 85652
USA

ATTENTION POSTMASTER: CHANGE SERVICE REQUESTED

BTW an International Association for All Trike Riders



Come Ride with Me
BROTHERS OF THE THIRD WHEEL